

## CHAPTER VI

### ENERGY CONSERVATION IN AIR CONDITIONING SYSTEM

#### Introduction

In general, the industrial plant, warehouse, laboratory, and data processing room is designed for the specific processes enclosed. Processing steps, such as assembly, packaging, and material handling, together with essential manufacturing requirements for quality and economical manufacture of the product, determine the configuration and size of the building. Environmental conditions to be maintained in the building include proper temperature, humidity, air motion, and cleanliness. Airborne contaminants generated must be collected, cleaned, and treated before discharged from the building or return to the area.

For worker efficiency, the conditions should provide for comfort, prevent fatigue, allow communication, and not be harmful to health. They should include control of temperature and humidity or local cooling to avoid heat stress; suitably low noise level; lighting adequate for the work performed; and control of the noxious and toxic fumes.

#### Descriptions of the Air Conditioning System

In this factory, both central and room (split type) air conditionings have been employed. There are three major groups of the central type: water chiller, brine chiller, and office air conditioning.

The water chiller with a centrifugal compressor, is responsible for the manufacturing processes and the related controls of extruding, spinning and draw-twisting sections. The components in this water chiller group are:

- two centrifugal compressors\* (one standby) of 600 HP each,
- two cooling towers,
- two air-washers, and
- one fan coil unit.

The chiller design capacity is 450 tons of refrigeration. For more details, see Figure 6.1 thru 6.4 and Table F.1.

The brine chiller, as named by the factory personnel, is servicing the take up process. It is composed of:

- one reciprocating compressor of 100 HP<sup>π</sup>,
- two reciprocating compressors<sup>†</sup> (one standby) of 75 HP each,
- two cooling towers, and
- one air-washer.

The bigger chiller has a capacity of 80 tons of refrigeration and each of the smaller ones of 60 tons of refrigeration. Diethylene Glycol is added to the chilled water to decrease its freezing point. For more information, see Figure 6.5, Figure 6.6, and Table F.2.

Office air conditioning is the last group of the central type to be considered. Its components consists of:

- one reciprocating compressor of 40 HP,
- one cooling tower, and
- two fan coil units.

---

\* This is the CH-1 and CH-2 in Figure 6.1.

<sup>π</sup> This is the BCH-1 in Figure 6.5.

<sup>†</sup> This is the BCH-2 and BCH-3 in Figure 6.5.

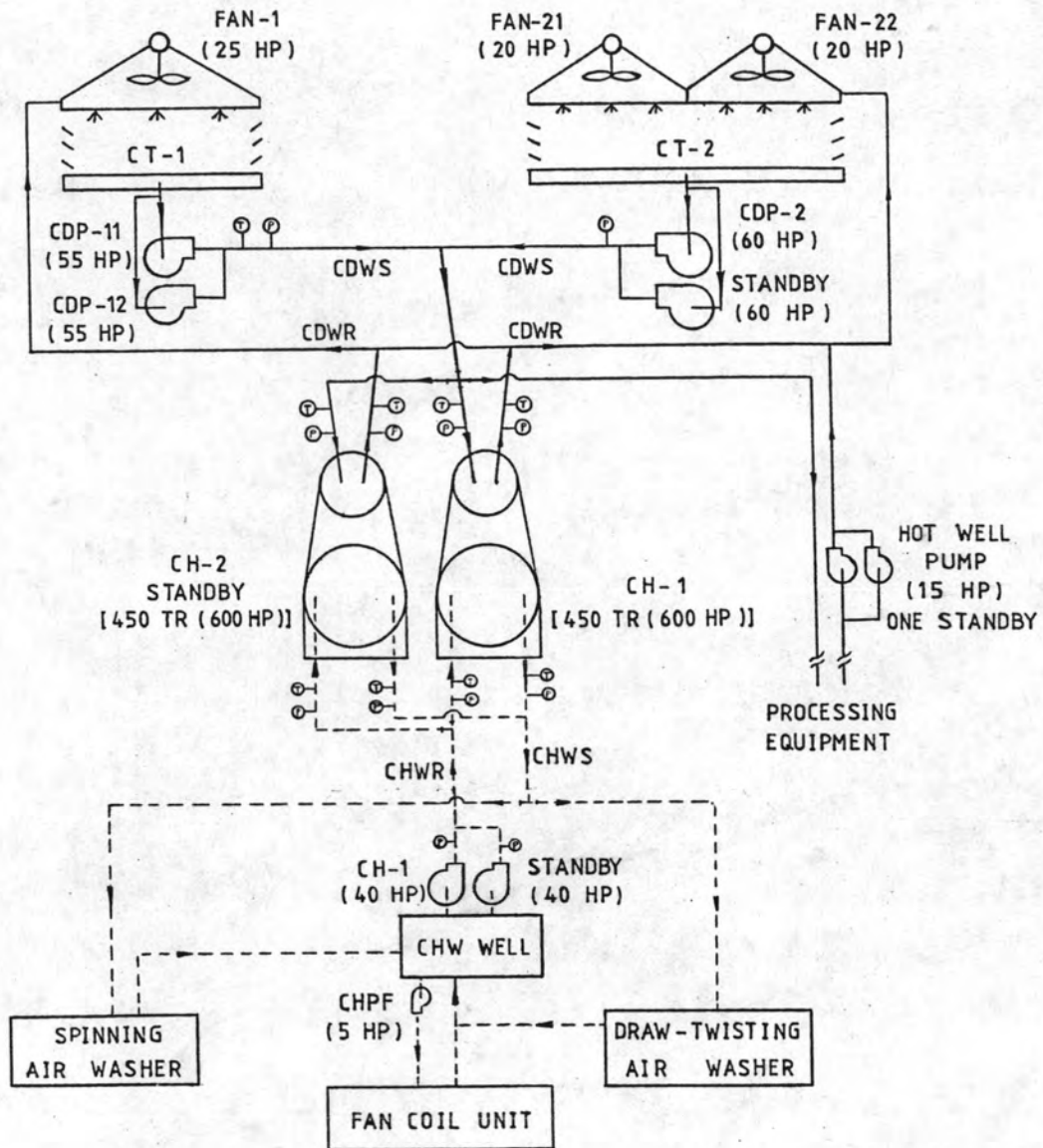

## LEGEND:

- CT = COOLING TOWER
- CDP = CONDENSER PUMP
- CH = CHILLER
- CHP = CHILLED WATER PUMP
- CHPF = CHILLED WATER PUMP FOR THE FAN COIL UNIT
- CHWS = CHILLED WATER SUPPLY
- CHWR = CHILLED WATER RETURN
- CDWS = CONDENSER WATER SUPPLY
- CDWR = CONDENSER WATER RETURN

Figure 6.1 Schematic Diagram of the Centrifugal Water Chiller System.

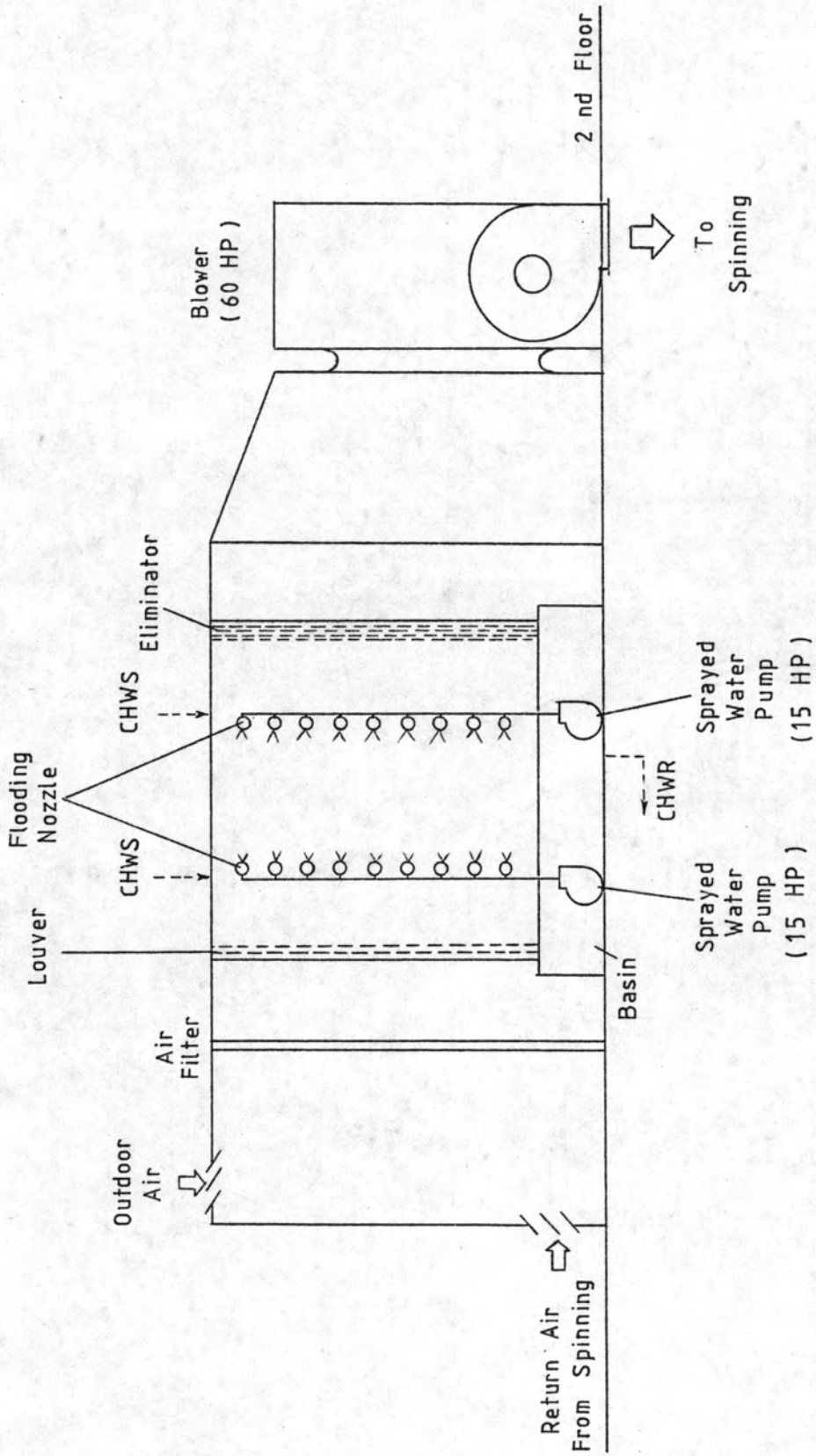

Figure 6.2 Schematic Diagram of the Spinning Air Washer on the Second Floor.

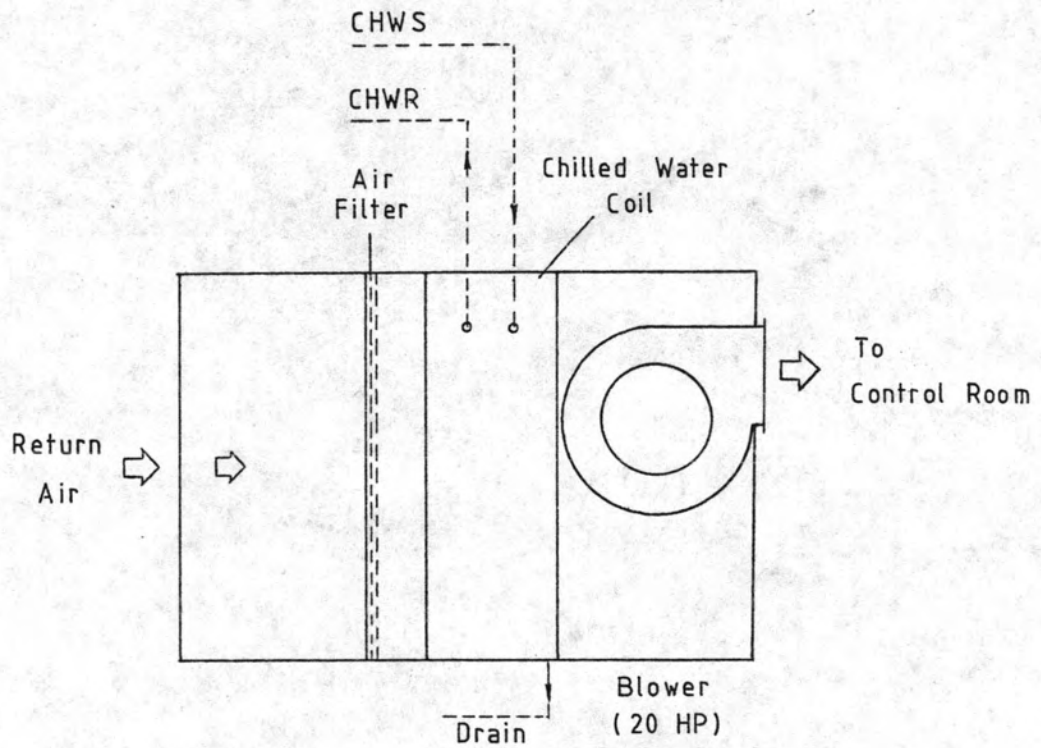

Figure 6.3 Schematic Diagram of the Fan Coil Unit on the Third Floor.



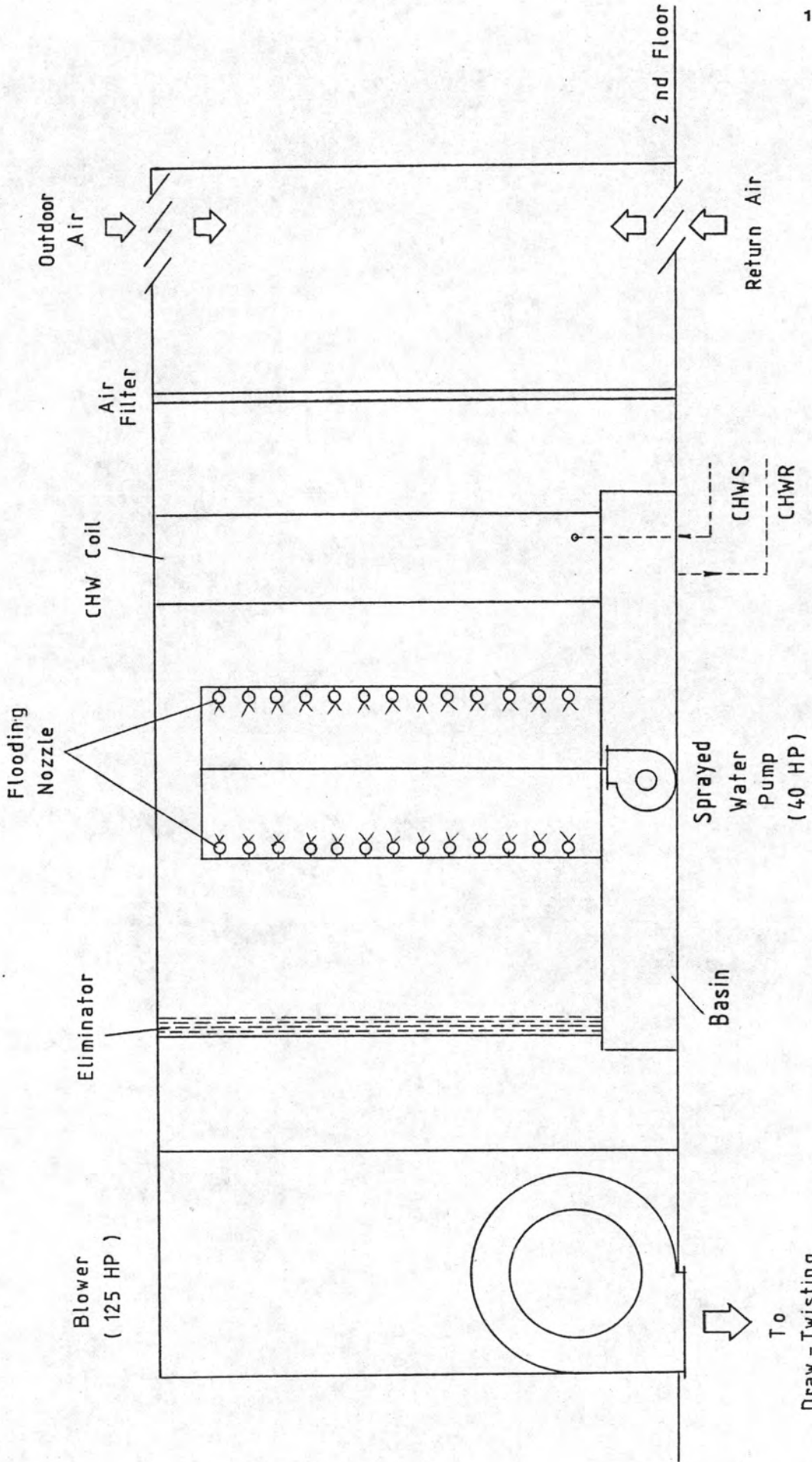
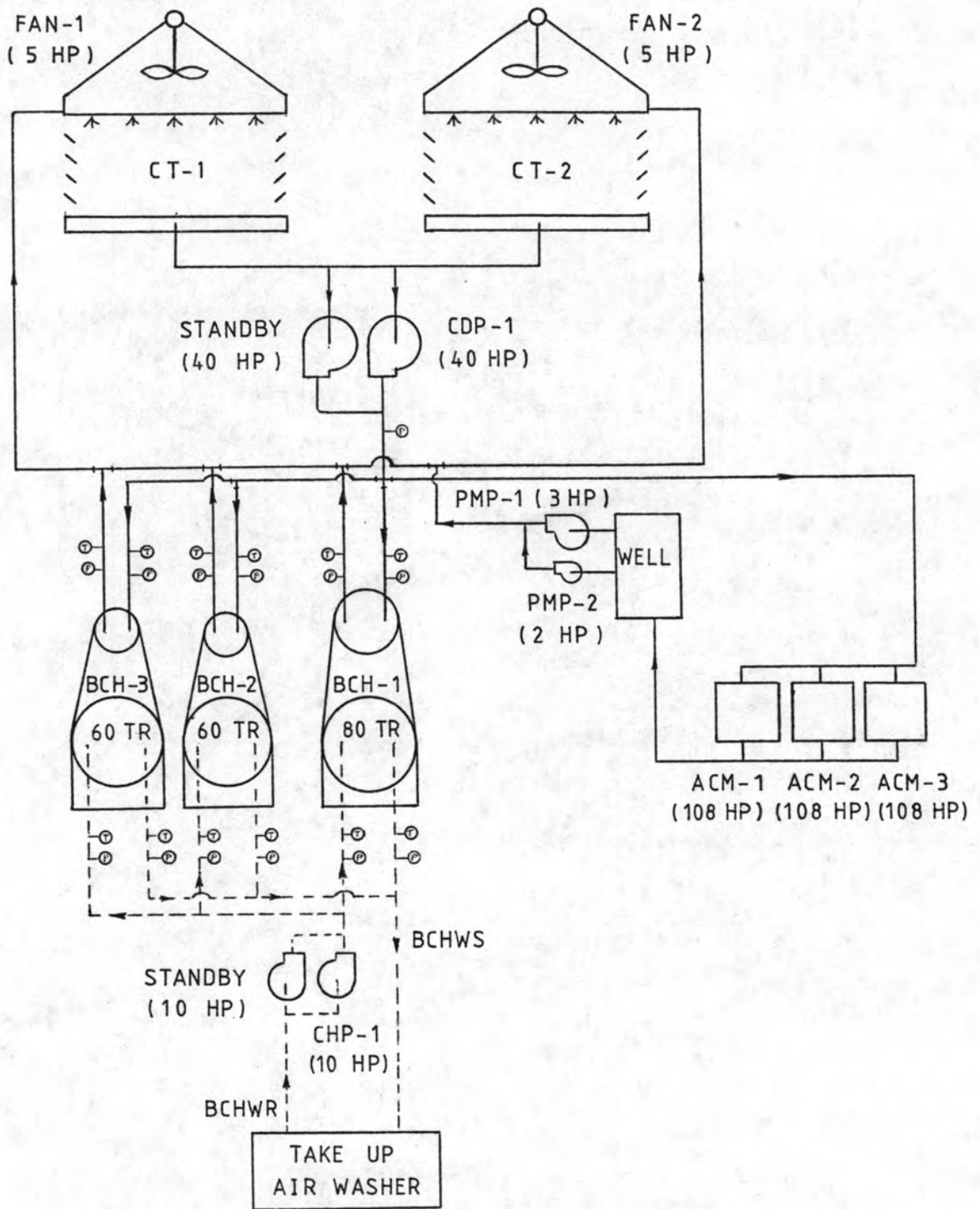

Figure 6.4 Schematic Diagram of the Draw-Twisting Air Washer on the Second Floor.



LEGEND:

PMP = COOLING WATER PUMPS FOR AIR COMPRESSORS.

BCH = BRINE CHILLER

ACM = AIR COMPRESSOR

OTHERS AS GIVEN IN FIG 6.1.

NOTE: BCH-1 and 2 RUN ALTERNATIVELY

Figure 6.5 Schematic Diagram of the Reciprocating Brine Chiller System.

LEGEND:

- BCHWR = BRINE CHILLED WATER RETURN
- BCHWS = BRINE CHILLED WATER SUPPLY

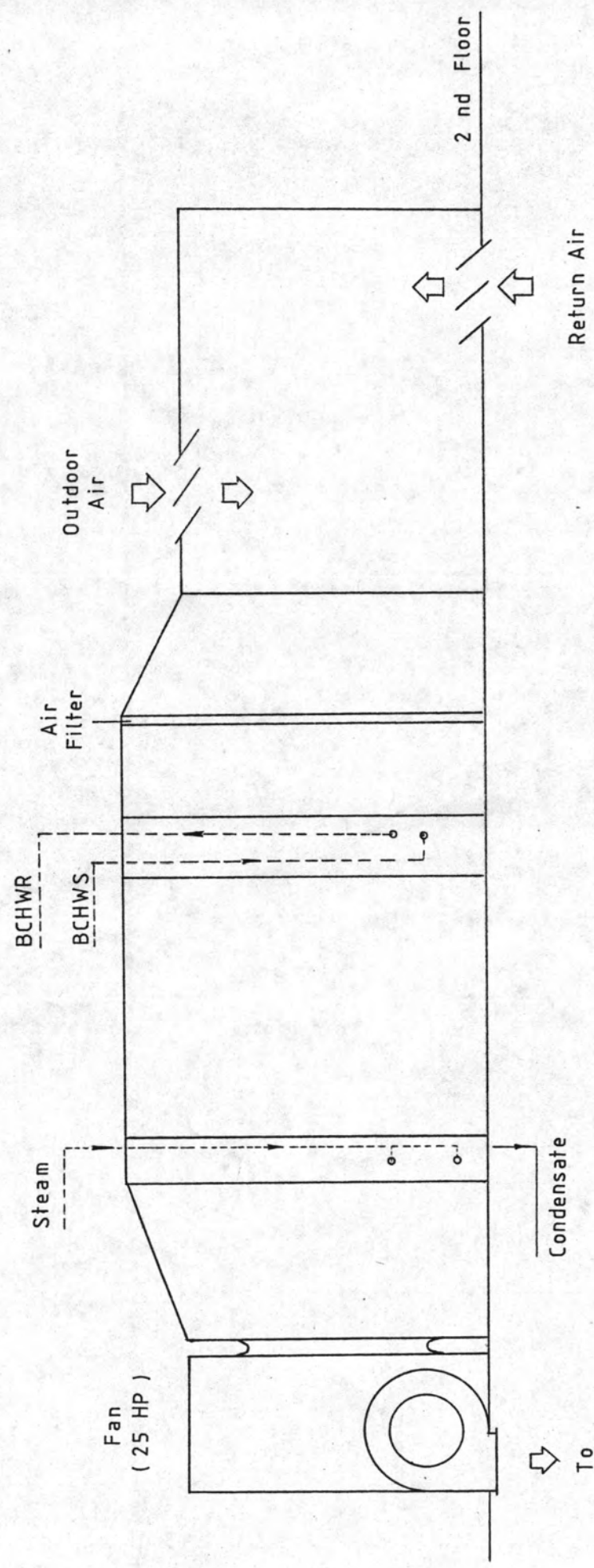

To  
Take-Up Room

Figure 6.6 Schematic Diagram of the Take Up Air Washer on the Second Floor.



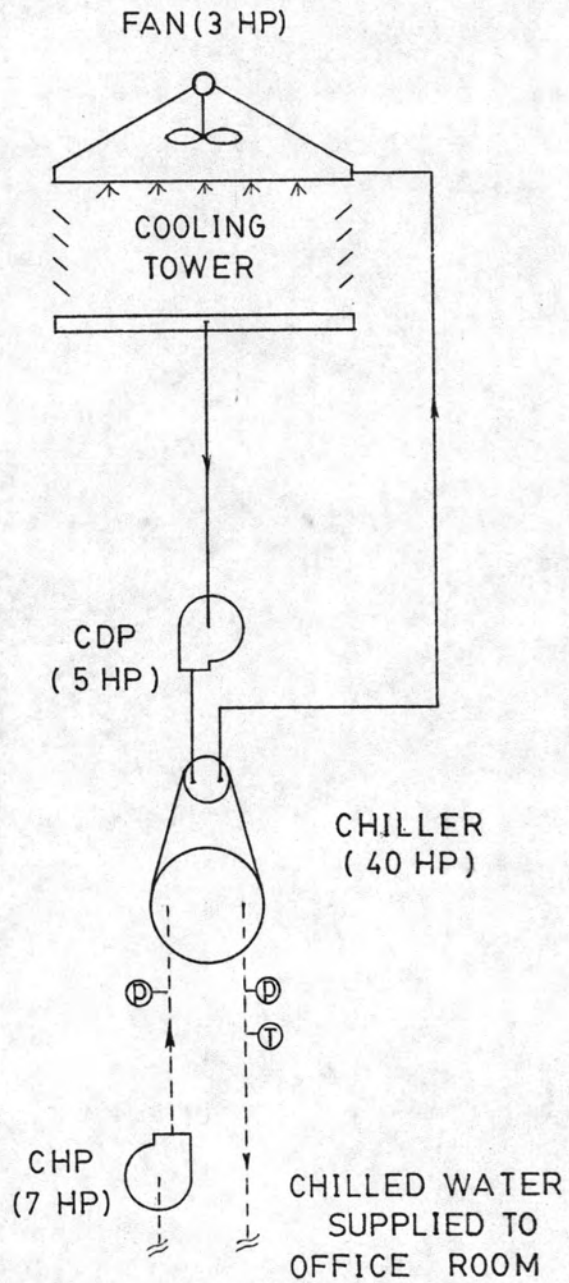

Figure 6.7 Schematic Diagram of the Reciprocating Water Chiller System for the Office Air Conditioning.

The diagram illustrating the office air conditioning system is given in figure 6.7. For more details, see Table F.3.

Packaged or room air conditioning systems, on the other hand, are used for small air conditioning requirements in the factory. The major areas currently using individual units include a production office, computer room, executive manager's room, and dormitories (some staff residences.)

#### Energy Consumption of the Air Conditioning System

For the current study, only the central air conditioning systems are considered. Electrical energy required by each piece of equipment can be estimated using data collected from the energy audit, see Appendix F.

Table 6.1 shows a breakdown of electricity consumption for each group of air conditioning equipment. A pie-diagram showing this breakdown is given in Figure 6.8.

#### Energy Conservation Opportunities (ECOs)

According to Table 6.1, the chiller compressors use  $(40.75 + 10.25 + 0.98)$  or 51.98% of the total electric energy of 18021.6 kWh which is the greatest proportion required by the air conditioning system. In this analysis, however, the chiller performance must be omitted as the measuring instruments installed for this area are not sufficient.

In this section, the air-side performance of air-washers and fan coil unit that produce cooling air for production spaces are studied. Analysis will be conducted to identify energy saving opportunities in the draw-twisting building as well as in the management offices

Table 6.1 Estimated Breakdown of Electricity Use - By A/C Equipment

A/C Equipment Group	Equipment *	Actual Electricity Consumption, kWh/day	%Consumption
Water chiller	Centrifugal compressor	7344.0	40.75
	Fans	2641.9	16.66
	Pumps	4705.2	26.11
	Subtotal.....	14691.1	81.52
Brine chillers	Recip. compressors	1848.0	10.25
	Fans	288.2	1.60
	Pumps	916.5	5.09
	Subtotal.....	3052.7	16.94
Office air cond.	Recip. compressor	176.1	0.98
	Fan	21.1	0.11
	Pumps	80.6	0.45
	Subtotal.....	277.8	1.54
Grand Total Energy for A/C.....		18,021.6	100.00

\* For more details, see Figure 6.1 thru 6.4 and Appendix F.

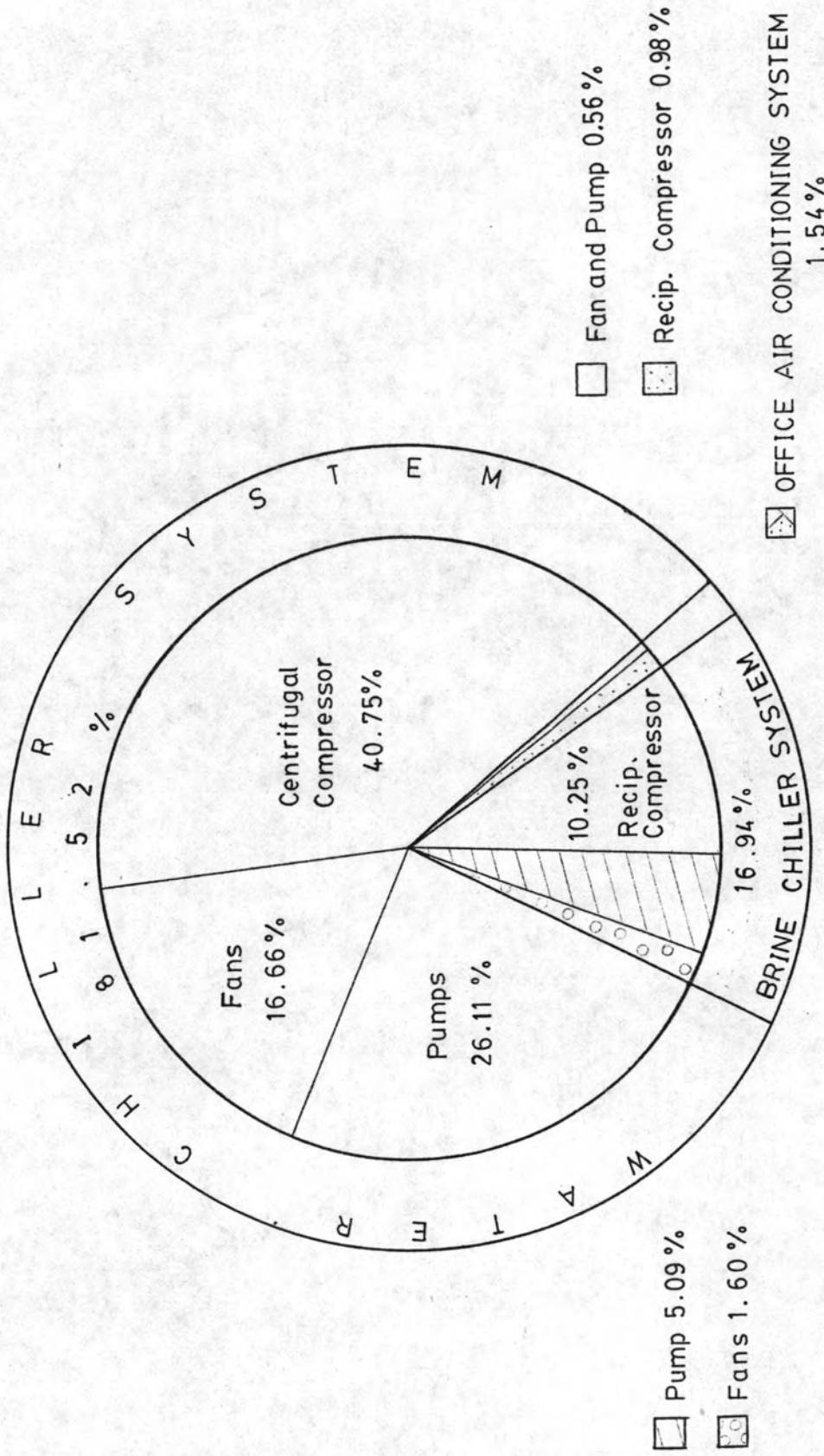

Figure 6.8 Pie Diagram for the Breakdown of Electricity Consumption in the Air Conditioning System.





where they were observed, during the walk-through audit, to be the areas that the wastage of energy was occurring.

#### Performance of Air Washers and Fan Coil Unit

A study was made to evaluate the performance of the existing air washers and fan coil unit. Unfortunately, data required in water-side evaluation for these units was not available. The measurement records for air-side and related computations are summarized in Table 6.2.

The last column of Table 6.2 indicates the amount of heat extracted from the air, outdoor and return air mixture, passing the air-conditioners.

It is obvious that heat load of 4,371,310.35 Btuh (365 TR) handled by the water chiller group accounts for about 81 percent of the chiller design capacity of 450 TR. The air washer for the take up process handles about 324,710.55 Btuh (27 TR)\* which accounts for only 20 percent of the two brine chillers' design capacity of 140 TR.

---

\* To obtain a correct performance, a closer investigation is essential since the make-up air is reheated to the final condition by steam supplied, see Figure 6.6

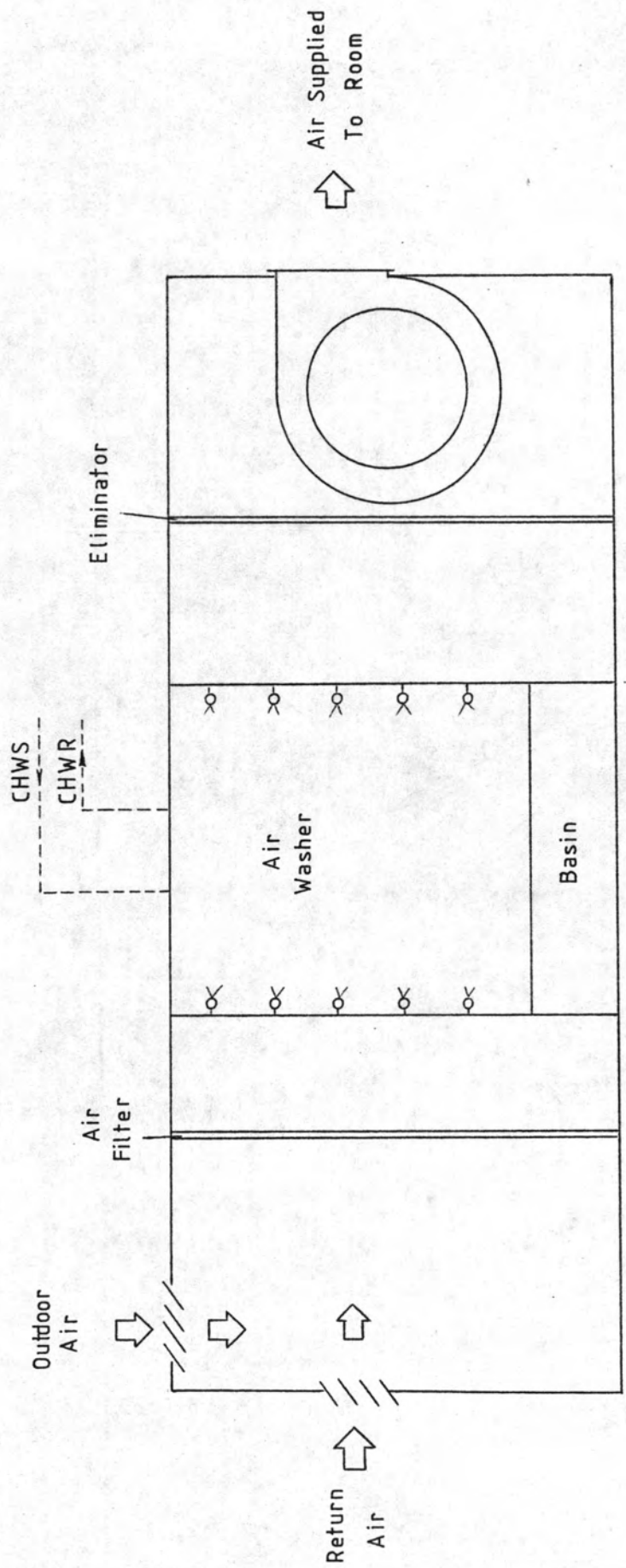

Figure 6.9 A Simplified Illustration of an Air Washer.

Table 6.2 Air-side Measurement Records and Performance Calculations (for May 24, 1986)

Unit Item	Equipment Face Area ft <sup>2</sup>	Face Velocity m/s	CFM	Conditions of Air				Calculated Cooling Capacity, Q Btu/hr (or TR)
				Entering		Leaving		
				WB °C	DB °C	WB °C	DB °C	
<u>For the Water Chiller Group:</u>								
1. Spinning AWSR	74.8	3.25	47,855	21.5 (70.7)	30.5 (86.9)	9.0 (50.0)	10.0 (50.0)	3,294,816.75 (275. TR)
2. Draw-Twisting AWSR	287.5	2.75	155,635	20.0 (68.0)	25.0 (77.0)	19.0 (66.2)	20.0 (68.0)	980,500.50 ( 82. TR)
3. Fan Coil Unit	28.0	2.15	11,851	16.0 (60.8)	27.0 (80.6)	14.5 (58.1)	24.0 (75.2)	95,993.10 ( 8 TR)
Sub - total cooling capacity, Q, for the water chiller group is 4,371,310.35 Btu/hr (365 TR).								
<u>For the Brine Chiller Group</u>								
1. Take-Up AWSR	42.5	3.75	31,373	11.5 (52.7)	19.0 (66.2)	9.0 (48.2)	15.0 (59.0)	324,710.55 ( 27 TR)

Remarks: 1. All temperatures in parentheses ( ) are of degree Fahrenheit.

2. Calculated cooling capacity, Q = (4.5) (CFM) ( ΔH ).

3. "AWSR" in this table stands for "air washer."

### Analysis of the Draw-Twisting Building

This building is used for the draw-twisting process, inspection and packaging, textile laboratory, and machine maintenance. The draw-twisting process occupies the majority of the building space.

Energy saving opportunities were observed during a walk-through audit, including:

- (1) construction of a fiberglass ceiling, two (2) meters below the existing roof;
- (2) closing the door between the draw-twist section and the warehouse whenever it is not needed; and
- (3) closing the two finished product handling channels between the packing area and the warehouse when they are not needed.

Upon completion of these measures, cooling load reduction and lighting illumination improvement may also be achieved.

#### ECO 1 Installation of a Fiberglass Ceiling

By installation of the ceiling, reduction of heat gain through the roof and through the wall (above the proposed ceiling) can be anticipated.

1) Heat gain from the roof (for more details, see Appendix G.1):

without fiberglass ceiling .....	3,487,471	Btu per day.
with fiberglass ceiling .....	1,816,729	Btu per day.

Therefore, heat gain thru the roof is reduced by 1,670,742 Btu/day.



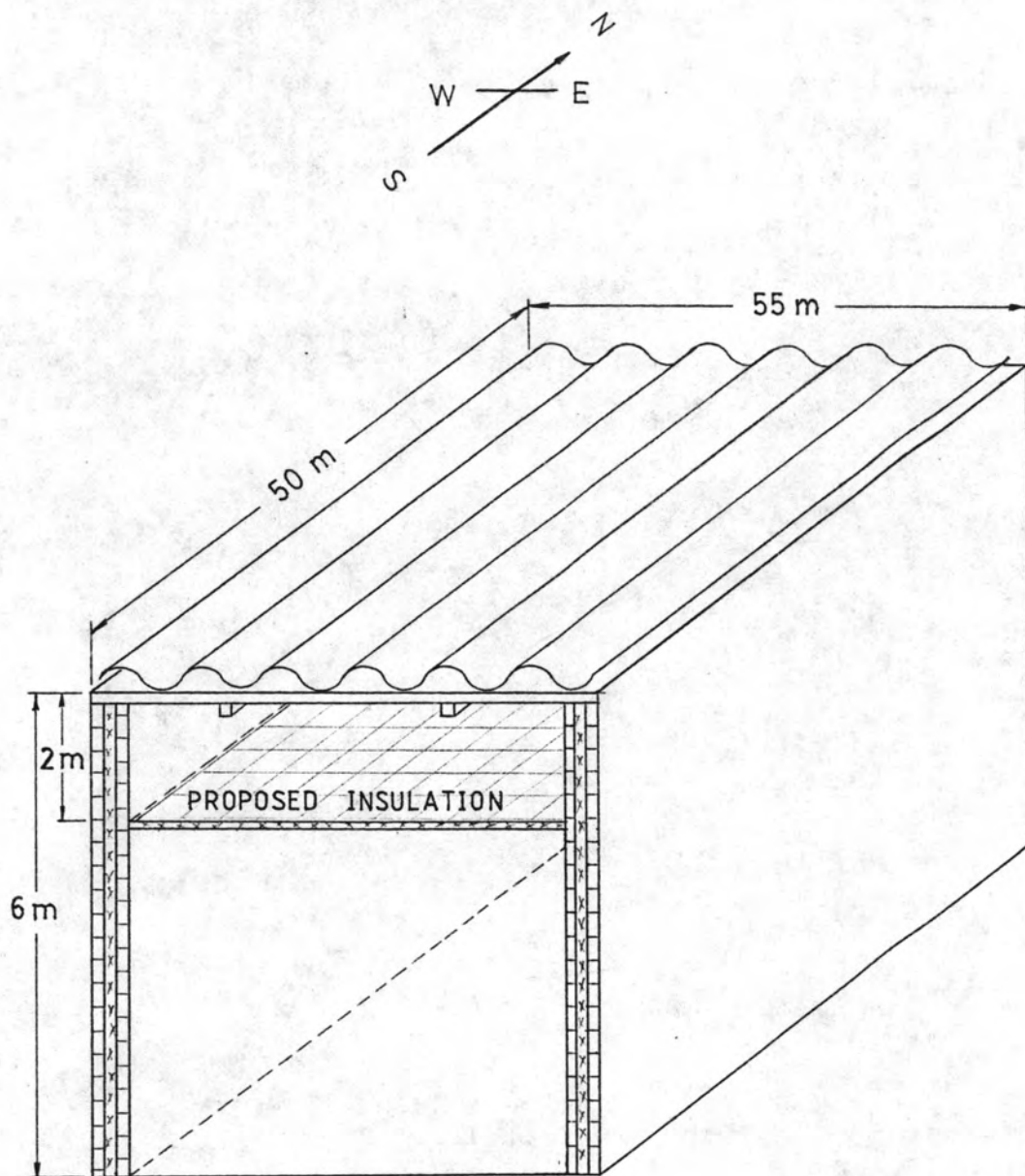

Figure 6.10 The Draw-Twisting Building with Proposed Insulation.

2) Heat gain thru walls reduced by this ceiling is 195,773 Btu/day. (see Appendix G.1, for more information.)

Based on the information obtained above, the amount of heat gain to the air-conditioned space is reduced by  $(1,670,742 + 195,773) = 1,866,515$  Btu/day or  $(1,866,515 \frac{\text{Btu}}{\text{day}}) (\frac{\text{day}}{24 \text{ hr}}) (\frac{\text{TR}}{12000 \text{ Btu}}) = 6.48 \text{ TR}$ .

Economic Analysis:

Investment\* ..... 750,000 baht.

Electricity for this air-conditioning system (actual),

see Table F.1 ..... 612.13 kW.

Air side performance of this system (see Table 6.2) .... 365 TR.

Therefore, electricity consumption rate is about  $(612.13/365) = 1.68 \text{ kW/TR}$ , which equals 2.62 baht/TR for the average cost of 1.56 baht/kWh (see Table 3.1).

The 6.48 TR of heat gain reduced is equivalent to electric energy of  $(6.48 \text{ TR} \times 1.68 \text{ kW/TR})$  or 10.89 kW which costs 16.99 baht. For the 24 hours of continuous running in April, this quantity of saving costs about 407.76 baht/day or 12,232.80 baht per month (April).

Using this peak month saving as a basis, the above investment requires 5 years and 2 months to recover. The payback period identified by this study indicates that the investment is not an attractive one.

---

\* This investment includes fiberglass, labor and other miscellaneous expenses as estimated by the Microfiber Industries Limited based on the price list issued on February 7, 1985.

ECO 2 Closing the Door Between the Draw-Twisting Section  
and the Warehouse when It is not Needed

According to a measurement taken on May 24, 1986, the following data are obtained:

The door opening area, 1.5 m x 2 m, ..... 3.0 m<sup>2</sup>

The leaving air velocity (average) ..... 1.5 m/s.

Hence, the cooling air is flowing out by 4.5 m<sup>3</sup>/s.

Since 1 m<sup>3</sup>/s = 2118.88 CFM, the cooling air is leaving from the draw-twisting space by about 9535 CFM. To determine heat gain, we employ the equation

$$Q = (4.5) (\text{CFM}) (\Delta H)$$

where  $Q$  = heat gain, Btuh

CFM = the volumetric rate of cooling air flowing out, 9535 Cu ft/min

$\Delta H$  = enthalpy difference of indoor and outdoor air, Btu/lb of dry air.

The computations for  $Q$ , based on outdoor conditions of April, can be illustrated as follows:

Average enthalpy at saturation of outdoor air (for April), see Table G.3 .....42.73 Btu/lb of dry air.

The room conditions:

dry bulb temperature .....24 °C (75.2°F),

wet bulb temperature .....20 °C (68°F),

and enthalpy at saturation.....32.42 btu/lb of dry air.

Therefore, the amount of heat gain ( $Q$ ) = (4.5) (9535) (42.73-32.42).  
or 442,376 Btu/hr (37 TR). With the electricity cost of 2.62 baht/TR

(see ECO 1), money saving of 96.94 baht/hr or 69,797 baht/month (for April) can be expected.

ECO 3 Closing the Two Finished Product Handling Channels when They are not Needed

This problem has been considered in the same way as the previous one.

The two channel face areas .....4.0 m<sup>2</sup>

The leaving air velocity (average) .....1.5 m/s.

Hence, the volume of cooling air leaving the space is 6.0 m<sup>3</sup>/s.  
or 6357 CFM (1 m<sup>3</sup>/s = 2118.8802 CFM).

Using the equation  $Q = (4.5) (CFM) (\Delta H)$ , where CFM = 6357, and  $\Delta H = 10.31$  Btu/lb of dry air (as found in ECO 2), the amount of heat gain is 294,933 Btu/hr (or 25 TR) which costs about 65.50 baht/hr or 47,160 baht/month during the peak month (April).

Analysis of the Administrative office Building

This two-storey building is located at the front zone of the production buildings (see Appendix A.) Most activities performed in this building occupy the space on the first floor, including management, nursery, accounting, and other office functions. Air conditioning required by this space is to comfort the occupants in each area. There are two kinds of air conditioning methods, the central type and the individual (packaged) one. The former serves a managing room and a clerical room while the latter serves a computer room, a nursery room, and a private office of the executive manager. The second floor area is rarely occupied, consisting of two meeting rooms and other empty ones. Therefore, emphasis will be given to the first floor, specifically to



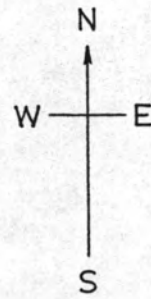
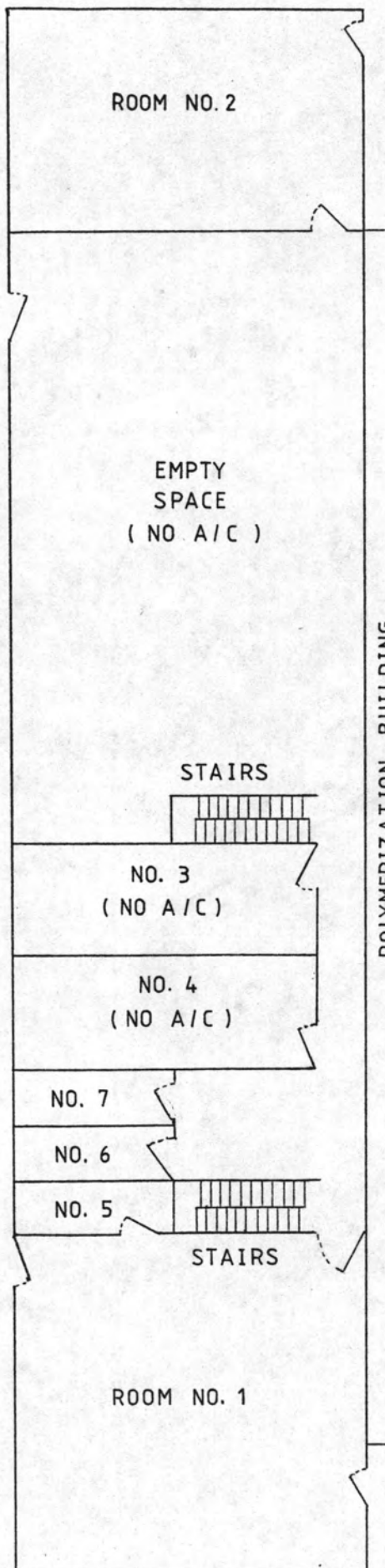

Descriptions (Activities) of the Rooms:

- No.1 Management & Accounting
- No.2 Clerical Paperwork
- No.3 Executive Manager
- No.4 Nursery
- No.5 Computer Room
- No.6 Gentleman Toilet
- No.7 Lady Toilet

Figure 6.11 The First Floor Plan of the Administrative office Building

the rooms being conditioned by the central air conditioning. Figure 6.11 shows a diagram of the first floor partitioning.

The possible energy saving opportunities for this building include:

- (1) reduction of sun load thru glass barriers;
- (2) closing the door that is always opened between room no.1 and the empty space (see Figure 6.11);
- (3) using chilled water from the well outside the production building as a cooling fluid and stop the existing office air conditioning equipment; and
- (4) raising the room temperature to  $25.5^{\circ}\text{C}$  ( $78^{\circ}\text{F}$ ) db and  $18.3^{\circ}\text{C}$  ( $65^{\circ}\text{F}$ ) wb to obtain a comfortable condition and save energy.

Before evaluating the above measures, it is necessary to know the expenses in removing each unit of heat load of the room. Therefore, the air conditioning load handled by the existing air conditioner was estimated. Table 6.3 gives the area of walls and roofs for room no.1 and 2. In this estimation, the northern side of room no.1 and the southern side of room no.2 are assumed to be free from solar heat gain as they are constructed inside the building (see Figure 6.11.).

Table 6.3 Areas of Walls and Roofs for Room No.1 and 2.

Item	Area, ft <sup>2</sup>				
	E	W	N	S	Ceiling
Room no.1	-	-	-	-	2422
Concrete wall	420	323	485	425	-
Glass window	65	200	-	-	-
Room no.2	-	-	-	-	1615
Concrete wall	227	237	485	243	-
Glass window	97	87	-	243	-

Heat gain to any specified space may be categorized as follows:

1. Room sensible heat (RSH) comprises

(1.1) solar gain thru glass = glass area x solar factor x correction factor;

(1.2) solar and transmission gain through wall and roof = area x trans. coeff. factor x equiv. temp. difference;

(1.3) transmission gain through glazing and building fabric (except walls and roof) = area x trans. coeff. factor x temp. difference;

(1.4) internal sensible heat gain from occupants, power, lights, etc.

2. Room latent heat (RLH) from infiltration, people, appliances, etc.

3. Outdoor air required for ventilation comprises

(3.1) outdoor air sensible heat = CFM x temp. diff. x 1.09;

(3.2) outdoor air latent heat = CFM x grain/lb x 0.68.

Computation based on data recommended by the Carrier Handbook of Air-Conditioning Design (13) as well as those collected in Table 6.4 are summarized in Table G.4.

The central air conditioning system for the two offices possesses a group of equipment that requires electricity of 30.86 kW (see Table F.3). With the refrigeration load of 22 TR (from Table G.4), the system performance is  $(30.86 \text{ kW}) / (22 \text{ TR})$  or 1.403 kW/TR.

#### ECO 4 Reduction of Solar Heat Gain

The east glass window of room no.1 was observed to be exposed to direct sunlight in the morning. By introducing some appropriate shading devices or other means, reduction in heat gain to the conditioned space can be accomplished.

Assume that a 6 mm. Dark Coolgray Float of Thai-Asahi is employed. The over-all factor for solar heat gain thru ordinary glass will be 0.63. Computations, using this information as well as those given in Table G.5, are summarized in Table 6.4.

Generally, reduction of heat gain by transmission due to temperature difference can also be anticipated. In this case, however, the U-value for the glass, as provided by the manufacturer, of 1.1 Btu per (hr. sq ft. °F) is equal to that of vertical panels single flat glass of 0.25 in. thickness.\* Therefore, this type of reduction is impossible.

---

\* See Table 8, pp. 2-172, in the Handbook of Air Conditioning Heating and Ventilating, Third Edition (14).



Table 6.4 Solar Heat Gain before and after Installation of a 6 mm. Dark Coolgray Float Insulating Glass

Item	AM		SUN TIME					PM		Avg.heat gain Btu/(ft <sup>2</sup> .hr.)
	8	9	10	11	Noon	1	2	3	4	
With ordinary glass	164	149	105	48	14	14	14	13	11	46.9
With insulating glass	103.3	93.9	66.2	30.2	8.8	8.8	8.8	8.2	6.9	29.5
Sun load reduction	60.7	55.1	38.8	17.8	5.2	5.2	5.2	4.8	4.1	17.4

Remark: Heat gain thru ordinary glass are interpolations of those values between

10° and 20° North Latitude (see Table G.5).

## Economic Analysis:

The glass area (measured)..... 65 sq ft.  
 Average heat gain reduced (Table 6.5).... 17.4 Btu/(sq ft. hr).  
 Hence, total heat reduced..... 1131 Btu/hr.  
 The system performance (derived)..... 1.403 kW/TR.  
 So, with 1 TR = 12,000 Btu/hr, electricity consumption is  
 reduced..... 0.13 kW.  
 Since 1 kWh, Table 3.1, Costs..... 1.56 baht,  
 reduction in energy cost ..... 0.20 baht/nr.

The working time is 9 hours/day and 2700 hours/year.  
 Therefore, the expected saving = 540 baht/year (45 baht/month).  
 Investment ..... 3400 baht.\*

Hence, the simple payback period ..... 6 years 4 months.

ECO 5 Closing the Door Between Room No.1 and the Empty Space

A measurement taken at this region indicated that there is no velocity of air between the two areas while other doors are still closed. Some sudden wind, however, starts blowing as soon as one of the doors is opened.

Stamper & Koral (14) recommended in the Handbook of Air Conditioning Heating and Ventilating, on page 2-111, the infiltration load in summer be 800 CFM when the air is calm and a conventional 3 ft. door is opened. Using this data and the equation for heat gain through

---

\*The purchasing price for the Dark Coolgray Float as informed by the manufacturer, on July 10, 1986, is 47 baht per sq ft. This investment includes the material cost plus 10% more for labor and other miscellaneous expenses.

infiltration (see Table G.4, item "infiltration"), we obtain the heat gain from infiltration as follows:

$$\begin{aligned} \text{Infiltration by transmission gain}^* &= (800 \text{ CFM}) (17^\circ\text{F}) (1.09) \\ &= 14824 \text{ Btu/hr} \end{aligned}$$

$$\begin{aligned} \text{Infiltration by latent heat} &= (800 \text{ CFM}) (82 \text{ GR/LB}) (0.68) \\ &= 44608 \text{ Btu/hr.} \end{aligned}$$

Hence, total heat gain from infiltration = 59432 Btu/hr.

Since the performance of this air conditioning system is 1.403 kW/TR, this amount of heat gain equals 6.95 kW or 10.84 baht/hr (1 kWh = 1.56 baht). For the office with 2700 hours per year, electricity charge of 29268 baht (or 2439 baht/month) can be saved with a "no-cost" investment.

#### ECO 6 Utilizing Chilled Water of the Water Chiller as a Cooling Fluid and Shut-off the Office Air Conditioner

Based on the results revealed from the ECOs for the draw-twisting building and the air conditioning load estimated in Table G.4, a challenging ECO is discovered.

From ECO 2, the cooling load of the water chiller system is reduced by 489,146 Btu/hr (41 TR) which is about 1.9 times the cooling load of the two office rooms (see Table G.4). Moreover, the 450 TR (600 HP) chiller of the water chiller system presently runs at about 68% of its nameplate capacity (see Table F.1). Therefore, energy saving can be obtained both by eliminating the existing office air conditioner and by improving the efficiency of the water chiller.

---

\* The office is opened between 8.00 a.m. and 5.00 p.m.

To implement this measure, most of the equipment and material required are available within the factory, including chilled water pipe and chilled water pump (the existing 7 HP pump is applicable, see Table F.3). Some minor investment, nevertheless, is necessary. This expense consists of the following items:\*

1. Additional piping (2"Ø, 18 m. long, 3.91 mm. thick).....	3000 baht.
2. Insulation (fiberglass 1" thick.).....	2000 baht.
3. Labor force (3 technicians, 5 days).....	3000 baht.
4. Others (welding, wire, etc.).....	500 baht.
Total.....	8500 baht.

#### Economic Analysis:

Electricity for the existing equipment, Table F.3,.... 30.86 kW.  
 Electricity for the proposed group..... 5.22 kW.  
 Reduction in electricity requirement..... 25.64 kW.  
 The office annual operation time..... 2700 hours.  
 Average electricity charge, Table 3.1,..... 1.56 baht/kWh.  
 Hence, the amount of energy cost saving is 107,996 baht/year  
 or 9000 baht/month.

The simple payback period is 29 days (approx. 1 month).

An improvement in the centrifugal chiller's efficiency is also possible by this measure. In general, we save a total of 5.6% of our chiller's energy consumption by raising the chilled water temperature

---

\* All items are estimated based on information obtained on August 1986.



one degree F (3,5). For the current energy consumption of 306.0 kW (see Table F.1), a reduction of 17.136 kW will be achieved by each degree incremental temperature of the chilled water returning to the evaporator. This amount of energy costs about 26.73 baht/hr or 72,171 baht/year for the 2700 hours of the office operation.\*

#### ECO 7 Resetting the Room Temperatures\*\*

A measurement taken at 3 p.m. of April 18, 1986 revealed the data as shown in Table 6.5. By raising these room temperatures to 78.0 °F db and 65.0 °F wb, a comfortable condition recommended by ASHRAE (see Figure H.1), electric energy involved can be reduced (see Table 6.6).

Consider Table G.4, the items that can be different, when the room conditions are reset, include:

TRANS. GAIN - EXCEPT WALLS & ROOF

SENSIBLE HEAT OF OUTDOOR AIR

LATENT HEAT OF INFILTRATION

LATENT HEAT OF OUTDOOR AIR

The computations, using the conditions of room no.2 (the worse case) as a basis, are summarized in Table 6.6.

It is noted that the amount of cooling load reduced of 1.8 TR accounts for 8.2% of the design estimate of 22 TR. For the system performance of 1.403 kW/TR, derived previously, this amount of cooling load is equivalent to electric energy saving of 2.53 kW.

---

\* This improvement is possible when the proposed measure works, i.e. during the period of the office opening.

\*\* A more precise calculation can be made using hourly outdoor conditions.

Table 6.5 Data obtained on April 18, 1986 (3.00 P.M.)

Item	Existing Conditions		ASHRAE Standard
	Room No. 1	Room No. 2	
Temperature, DB	23.5°C (73.4°F)	22.7°C (72.8°F)	25.5°C (78.0°F)
Temperature, WB	18.5°C (65.3°F)	17.0°C (62.6°F)	18.3°C (65.0°F)
Relative humidity, %	65	56.7	50
Dew point, °F	61.2	57	58
Moisture, GR/LB	80.6	69	71

Table 6.6 Calculations for Cooling Load Reduction after Resetting the Room Temperatures

Item	Existing Condition	Improved * Condition	Load Reduction
Transmission gain, Btuh	68,867	52,736	16,131
Sensible heat of outdoor air, Btuh	14,640	11,211	3,429
Latent heat of infiltration, Btuh	62,832	61,336	1,496
Latent heat of outdoor air, Btuh	34,558	33,735	823
Total	180,897	159,018	21,879 (1.8 TR)

\* Based on ASHRAE Standard, 78°F db and 65°F wb, see Table G.4 and Figure H.1.

Since 1 kWh of electricity costs 1.56 baht (see table 3.1), energy cost saving is (2.53 kW) (1.56 ¢/kWh) or 3.95 baht/hr.

For the office time of 2700 hours per year, the saving of (3.95 ¢/hr) (2700 hr/yr) or 10,665 baht/year (888.75 baht/month) can be expected with a "no-cost" investment.

### Summary

This chapter discussed the air conditioning system of the factory, including descriptions of the system, energy utilization, and identification of energy conservation opportunities.

Emphasis was aimed at the central air conditioning systems employed in this factory, including the centrifugal chiller system, the reciprocating brine chiller, and the reciprocating water chiller ones. Schematic diagrams for the piping and related equipment were also presented.

Electricity consumption by major equipment for each system was investigated and equipment of the centrifugal water chiller system was found to be the largest electricity consumer that required about 81.52% of the total electric energy of 18021.6 kWh per day used by the whole central air conditioning equipment of the factory (see Table 6.1 and Figure 6.8).

Air-side performance of air washers and fan coil unit were evaluated to estimate the status of such equipment. Then, ECOs were identified including three (3) measures recommended for the draw-twisting building and four (4) for the management office rooms. Analysis for each energy saving candidate gave a result as summarized in Table 6.7.



The results from the calculations for ECO 1 and ECO 4 indicated that retrofitting of an old building or system for energy saving can pay off an unattractive outcome. Energy conservation must be considered at the first stage of design and construction.

Table 6.7 A Summary of Energy Conservation Opportunities for the Air Conditioning System

Item	Potential monthly Saving, ₪	Investment Baht	Payback Period
ECO 1. Installation of fiberglass ceiling for the draw-twisting building	12,232.80	750,000	5 yr. 2 mo.
ECO 2. Closing the door between the draw-twisting building and the warehouse	69,797.00	none	immediately
ECO 3. Closing the two finished product handling channels	47,160.00	none	immediately
ECO 4. Reduction of solar heat gain to the office	45.00	3,400	6 yr. 4 mo.
ECO 5. Closing the door of the managing office	2,439.00	none	immediately
ECO 6. Utilizing chilled water of the centrifugal water chiller system for the office rooms	9,000.0	8,500	1 month
ECO 7. Resetting the office room temperatures	888.75	none	immediately

Remarks: 1. The ECO 1 and ECO 4 are not very attractive opportunities, other possible measures may be sought.

2. Computations are based on conditions of the peak month (April).