

CHAPTER 3

MATERIALS AND METHODS

This chapter details the materials and methods pertaining to the particular designs and experiments in the present thesis. Included within this chapter is: configuration of bio-fuel cell, reagents and electrical measurement used in the BFC experiments.

3.1 Configuration of Bio-Fuel Cell

The configuration of BFC used in this dissertation consists of two compartments, an anodic and a cathodic compartments. The anodic and cathodic compartments were constructed from clear acrylic plates for ease of monitoring the physical change inside the compartments. Both compartments were separated by a Neosepta[®] PEM (model CMS, ASTOM corporation, Japan) in all experiments. The typical configuration of the BFC is shown in Fig. 3.1.

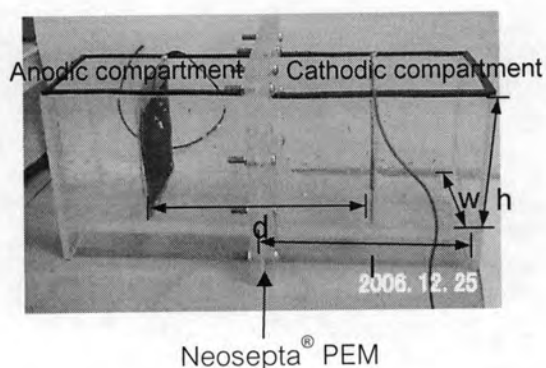

Fig. 3.1 Configuration of the BFC

where d : distance between anode and cathode [cm]

l : length of each BFC compartment [cm]

w : width of each BFC compartment [cm]

h : height of each BFC compartment [cm]

Since several configurations of BFC chamber were utilized in this dissertation for studying effect of physical parameters, then a series of seven digit code (xxxxxxx) was assigned to describe the physical structure of the BFC, as shown in Fig. 3.2.

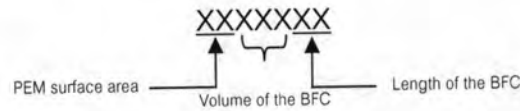

Fig. 3.2 Assigned code for the BFC compartment

Digit 1-2 represents the PEM surface area. Digit 3-5 explains the volume of each compartment. Digit 6-7 describes length of each BFC compartment. For example, the chamber code 2525010 represents a BFC that has PEM surface area of 25 cm^2 with 250 ml volume of each compartment, and the width of chamber is 10 cm.

3.2 Component in the Bio-Fuel Cell

Lyophilized *S. cerevisiae* (Baker's yeast; Fermipan[®]) was used as a microorganism throughout this dissertation since it exhibits tolerance for wide operating conditions. Furthermore it is relatively easy to culture. It was stored at 4°C in a refrigerator. It was leaved at room temperature for 15-30 mins before starting the experiments. Glucose (Fluka) was used as the organic substrate or fuel in the BFC. Phosphate buffer (PB; 0.1M, pH 7) was prepared from Na_2HPO_4 and $\text{NaH}_2\text{PO}_4 \cdot \text{H}_2\text{O}$ in de-ionized water. It is used to control the pH in the BFC system. All chemicals were used without further purification. All experiments were performed in batch operation and were carried out at temperature of $26 \pm 1^\circ\text{C}$.

Five different materials such as carbon fiber (CF: Acelan, Korea), silver (Ag: commercial grade, Thailand), nickel (Ni: Alfa Aesar, USA), stainless steel (St: S304, Thailand) and aluminum (Al: commercial grade, Thailand) were used as electrode in the BFC. The same electrode materials were used for both compartments which made it symmetrical in configuration. All electrodes were cleaned using ethanol and stored in de-ionized water prior to use. Three types of electron mediator such as methylene blue (MB), neutral red (NR) and rhodamine B (RhB), all from Tokyo Kasei Kogyo Co., Ltd.,

Japan, were utilized for investigation of the effect of mediator. For electron acceptor, ferricyanide (Wako Pure Chemical Industries, Ltd., Japan) and oxygen were studied. Air pump was used to bubble air into the cathodic compartment for supplying oxygen to the solution. The flow rate was ~ 500 ml/min. The schematic of the BFC is shown in Fig. 3.3.

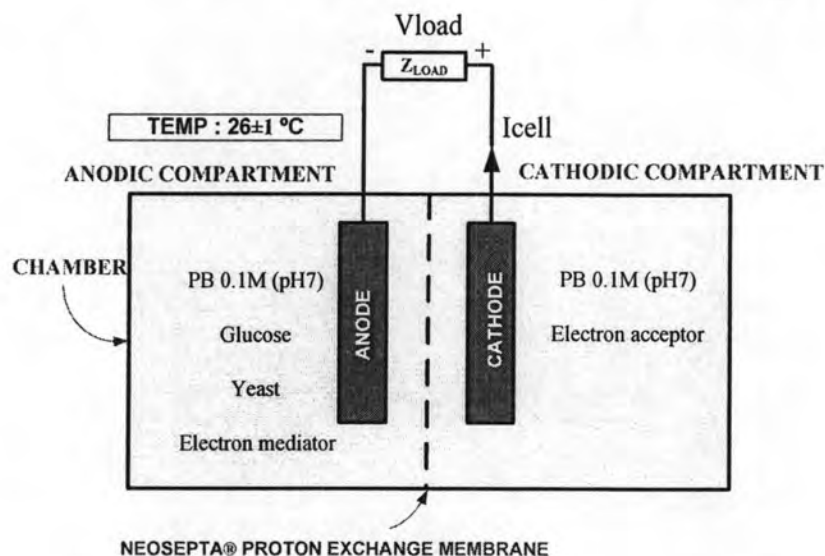

Fig. 3.3 Schematic of the BFC in the experiments

3.3 Electrical Measurements

3.3.1 Bio-Fuel Cell Performance

The BFC performances were investigated by observing the generated voltage, current density and power density supplying to the external load. The voltage generated by the BFC was measured using a laboratory made measuring system. The system was controlled by a PIC16F877 microcontroller. The generated voltage (V_{load}) was recorded every 30 seconds and sent to the computer via serial port RS-232 (Fig. 3.4). VCMETER is the program for recording the data from the measuring system. This program was developed using Dephi. The BFC characteristic was investigated using a series of resistance load across the anode and cathode. The value of resistor is in the range from 100Ω to $100\text{ k}\Omega$. It was connected to the BFC after the BFC has been operated for about 1 hour and 30 minutes and the load was changed every 15 minutes. The load resistance was varied from the highest resistance value ($100\text{ k}\Omega$) to the lowest resistance value (100Ω).

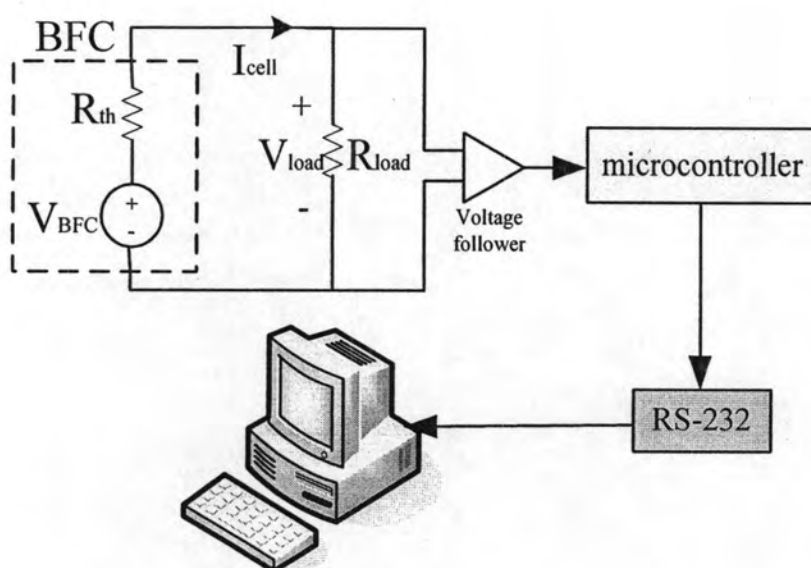

Fig. 3.4 Schematic of the BFC connecting to the measuring system

3.3.2 Electrical Impedance

The electrical impedance characteristics of the BFC were studied by using ac-impedance measurement. An ac-impedance analyzer (Solartron, model SI 1260) was used to vary the range of frequency between 0.05 Hz and 10 MHz. The frequency was varied from high frequency to low frequency. The ac voltage signal and dc bias were set at 200 mV and 0V, respectively.



Fig. 3.5 Ac-impedance analyzer