



CHAPTER IV

RESULTS AND DISCUSSION

4.1 Onset Volume of Crude Oil Sample

Before asphaltene deposition experiments were performed, the instantaneous onset volume was determined in order to be able to choose the appropriate precipitant concentration to study. A sample of the effluent from the deposition apparatus was taken by a micropipette and placed under the microscope to detect the presence of precipitated asphaltenes. The instantaneous onset volume was measured to be around 40 vol% C7 for Oil A. The results can be seen in Figure 4.1. Precipitated asphaltenes can be seen as black particles under the microscope as shown in circle of Figure 4.1 (d).

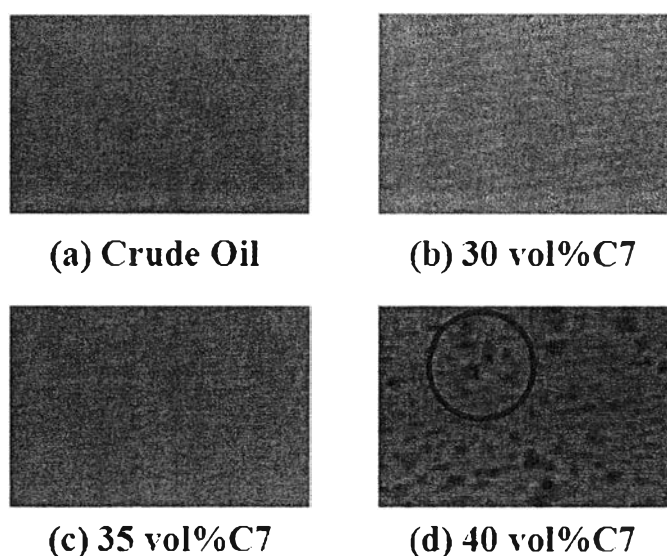

Figure 4.1 Micrographs showing the effluent of heptane in oil at different concentrations (Onset volume of studied crude oil is around 40 vol% C7).

To study asphaltene deposition at low heptane concentration experiments were performed at precipitant concentrations less than or equal 30 vol% C7, where no asphaltenes are detectable by microscopy.

4.2 Modification of the Experimental Apparatus

During the shutting down procedure of the deposition apparatus, the pressure profile of the system would suddenly change due to the bleed to the atmosphere and such a sudden change could lead to deposit removal. In order to prevent the deposit removal due to pressure changes, a micro-splitter valve and a micro-metering valve were added to the apparatus to ensure that the pressure in the system would slowly release and the surging fluid would not leach the deposit away. Figure 4.2 shows asphaltene deposition apparatus used in this work. After performing an experiment, the micro-splitter valve was closed to prevent fluid from surging through the system. The micro-metering valve was opened to lightly release the pressure in the system. The capillary was removed and drained by holding the outlet against a piece of paper towel. A syringe was used to inject air through the capillary tube to force any residual liquid out of the capillary.

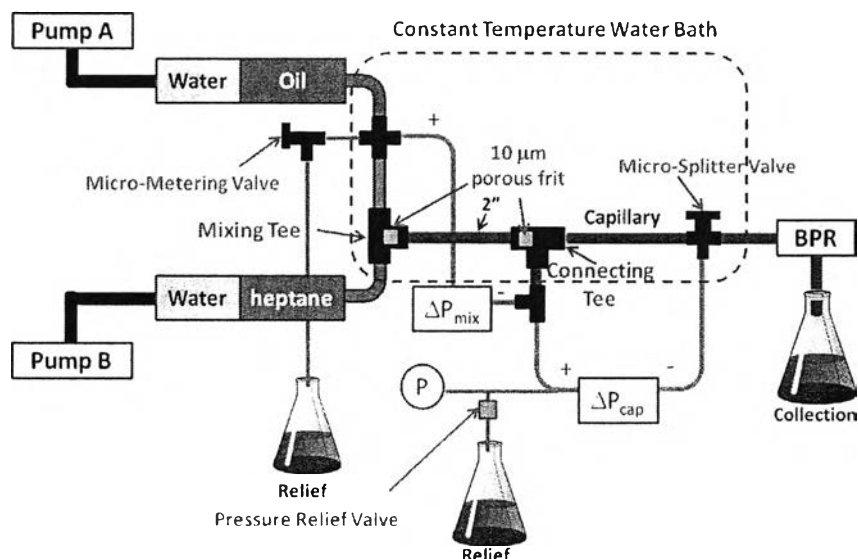

Figure 4.2 Asphaltene deposition apparatus used in this work.

4.3 Electron Microscopy of Deposits: Mixing Validation

As mentioned before, CFD simulations by Hoepfner (2010) suggest that the oil:heptane mixture will be well mixed if a 2-inch stainless steel capillary with a

0.03-inch ID connects the mixing tee to the capillary as shown in the Figure 2.6. Due to density of heptane is lower than that of oil the highest heptane concentration would be present at the top of the capillary. To confirm that the proper mixing is obtained in this apparatus, three possible deposit locations are proposed. First, if the deposit is formed only at the top of the capillary or at the side of the capillary that the heptane enters from, it suggests that the mixing is poor. Second, if the deposit is thinner at the bottom of the capillary compared to the top, it indicates that there is likely some improper mixing in the system, but asphaltenes are still depositing at a concentration below the onset point. Third, if the deposit is formed uniformly around the entire capillary, it indicates proper mixing. After experimentation was performed, the deposits were visualized with scanning electron microscopy (SEM) on a FEI Quanta 200 3D instrument operating in low vacuum mode. Figure 4.3 (left) shows a new and clean 0.02" ID capillary. Figure 4.3 (right) shows a 0.02" ID capillary of a crude oil blank which ran for 4 hr under the same conditions as a normal run. From left figure, it can be seen that the edge of the capillary is well defined and the roughness of the metallic surface can be identified. From the right figure, it can be seen that there is some oil trapped in the surface roughness of capillary. As will be seen shortly, if asphaltene deposits are present, they will appear smooth.

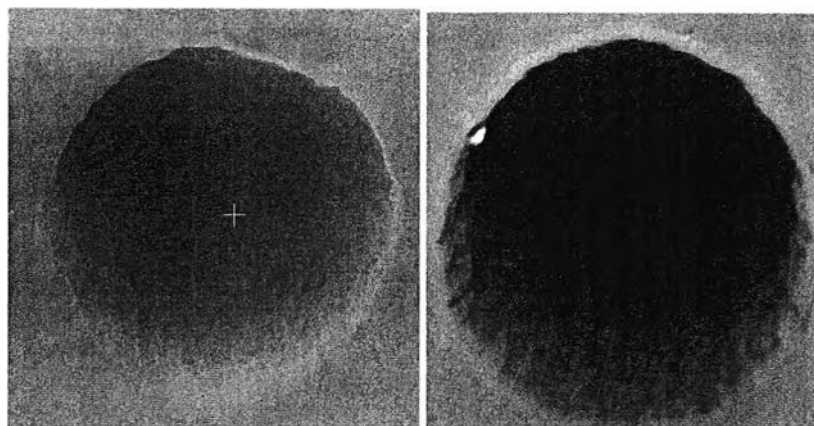

Figure 4.3 SEM images of a clean, unused capillary (left) and control experiment which ran for 4 hr under the same conditions as a normal run (right). Notice the visible roughness on both the capillary's walls.

Figure 4.4 shows a SEM image of a capillary inlet (left) and outlet (right) after an experiment performed with Oil A at 30% heptane in a 0.02" ID capillary for 7 hours. The deposit is roughly formed around the entire capillary, indicating that the system has proper mixing. The deposit is thinner at the outlet, supporting the capillary length comparison experiment performed by Hoepfner (2010). Figure 4.5 and Figure 4.6 show two additional experiments at the same conditions as Figure 4.4. A large solid item at the bottom of the capillary outlet in Figure 4.5 is believed to be a contaminant that likely adhered during transportation to the electron microscopy laboratory. Energy Dispersive X-Ray Spectroscopy (EDX) did not detect the presence of carbon, thus we conclude that it is a contaminant.

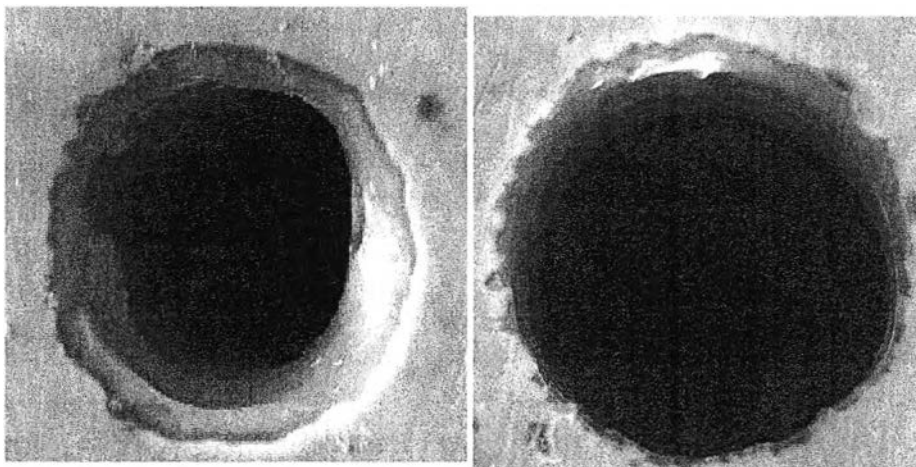

Figure 4.4 Image of capillary inlet (left) and outlet (right) with SEM. Experiment was performed at 30% heptane in a 0.02" ID capillary, Run 1. Notice the deposit roughly uniform radially at the capillary inlet.

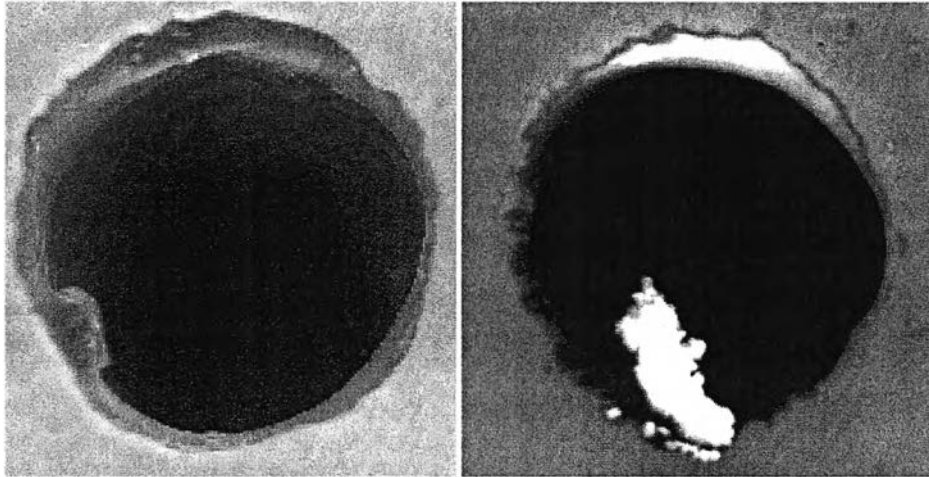

Figure 4.5 Additional reproducibility deposition experiment, Run 2. Same conditions as in Figure 4.4. The large material found at the bottom of the capillary outlet (right) is a contaminant. See text for rationale.

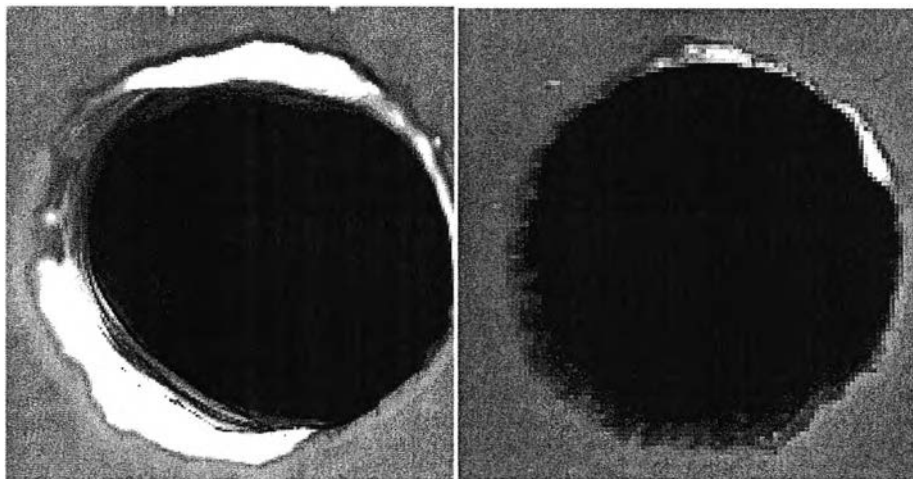

Figure 4.6 Additional reproducibility deposition experiment, Run 3. Same conditions as in Figure 4.4.

Figure 4.7 shows the pressure drop profile results of the deposition experiments which were conducted at 30% of heptane in Oil A flowing in a 2'' length capillary with 0.02'' ID at 60 °C for the SEM images that are found in Figures 4.4-4.6.

In Run 1, the light blue line, the pressure drop increases gradually indicating that an asphaltene deposit is building up on the wall. After 3.5 hours, the pressure drop starts to decrease. This occurrence can most easily be explained by the fact that pieces of the asphaltene deposit can break away from the capillary wall and flow into the bulk causing a decreasing in pressure drop. For the purpose of obtaining SEM images of the asphaltene deposit on the capillary wall, runs 2 and 3 were performed. And, these runs were stopped before any decrease of the pressure drop occurred, avoiding any detectable loss of the deposit. As can be seen, the deposits are roughly uniform radially, which indicates that the oil and heptane are well mixed.

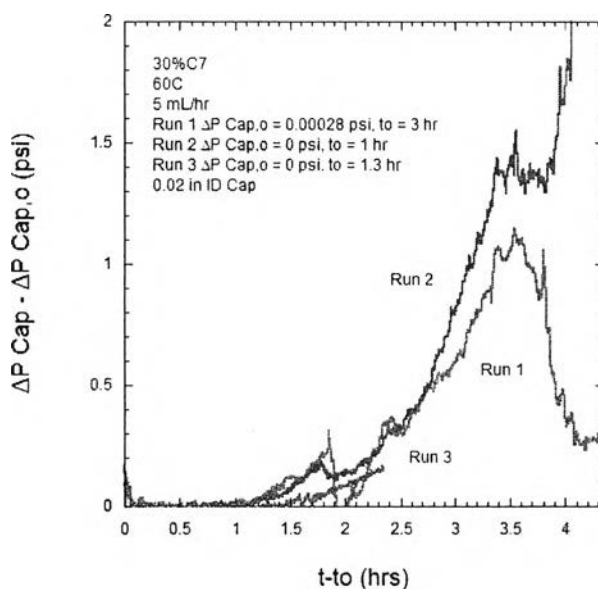

Figure 4.7 Pressure drop profiles of deposition results from Run 1, Run 2 and Run 3 for the SEM images found in Figures 4.4-4.6.

4.4 Extend Study: Investigating the Behaviour of a Second Crude Oil, Oil W

To check for wide applicability of the results for Oil A, experiments were performed with an additional crude oil, Oil W. The asphaltene content and viscosity of the second oil is less than Oil A, 15 times and 2 times, respectively. The deposition experiments for Oil W were performed in both 0.01" ID and 0.005" ID capillaries in order to improve the sensitivity of deposit detection by pressure drop

measurements. The 0.01" ID and 0.005" ID capillaries had a roughly circular inlet, but showed significant irregularities, as seen in Figure 4.8.

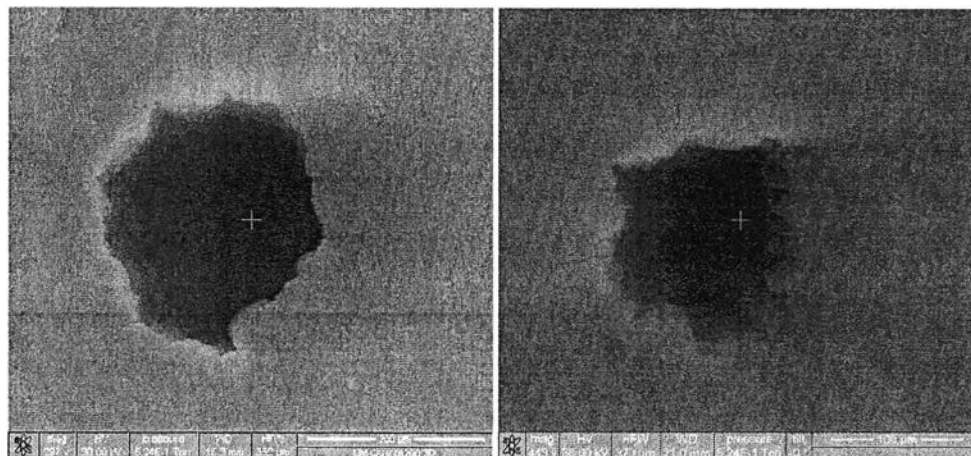

Figure 4.8 SEM images of 0.01" ID capillary (left) and 0.005" ID capillary (right).

The onset volume of Oil W was determined to be around 35 vol% heptane at 60°C and 25% heptane at 25°C by the same procedure as outlined for Oil A. Figure 4.9 and Figure 4.10 show SEM images of the capillary inlet and outlet at different heptane concentrations and temperatures in a 0.01"ID capillary. The deposit is roughly uniform and thinner at the outlet, which supports the results from the previous oil.

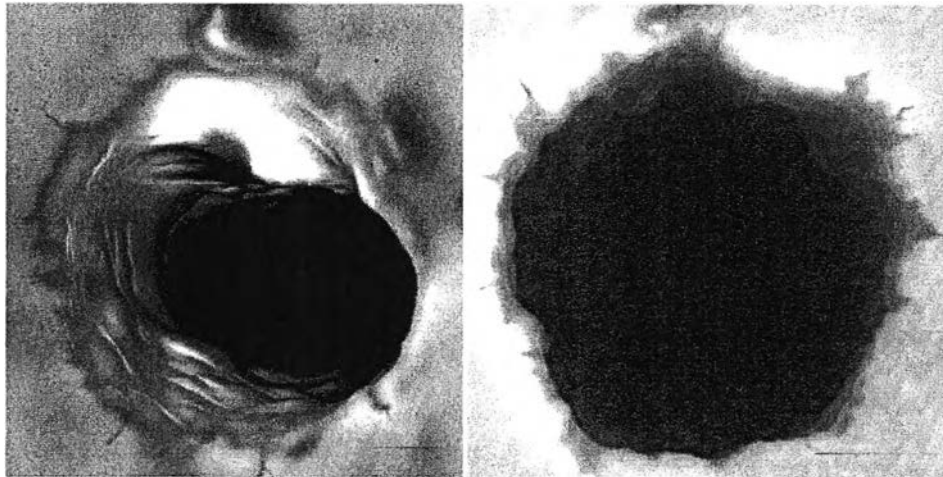

Figure 4.9 SEM images of capillary inlet and outlet for the Oil W deposit generated in a 0.01 inch ID capillary with a 1 foot length and 35% heptane at 60 °C.

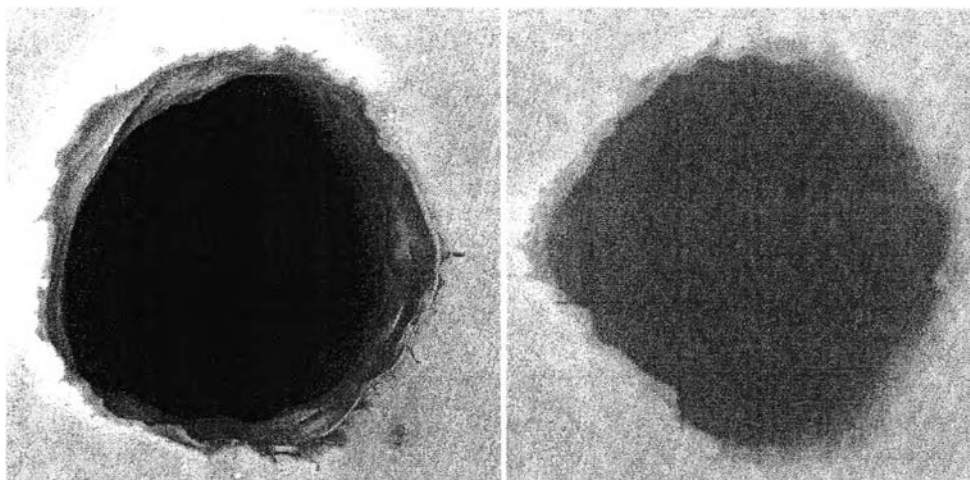

Figure 4.10 SEM images of capillary inlet and outlet for the Oil W deposit generated in a 0.01 inch ID capillary with a 1 foot length and 25% heptane at 20 °C.

The 0.005" ID capillary was used to improve the sensitivity of the deposit detection. Figure 4.11 shows pressure drop vs. time for 35% heptane at 60 °C in 0.01"ID and 0.005"ID capillaries. From the Hagen-Poiseuille equation, pressure drop is inversely proportional to r^4 , thus a small inner diameter change due to a deposit forming will induce a large pressure drop. The results indicate that the sensitivity of the deposit

detection improved when an experiment was performed on smaller ID capillaries. However these experiments were performed at constant volumetric flow rate and neglected the effect of shear rate.

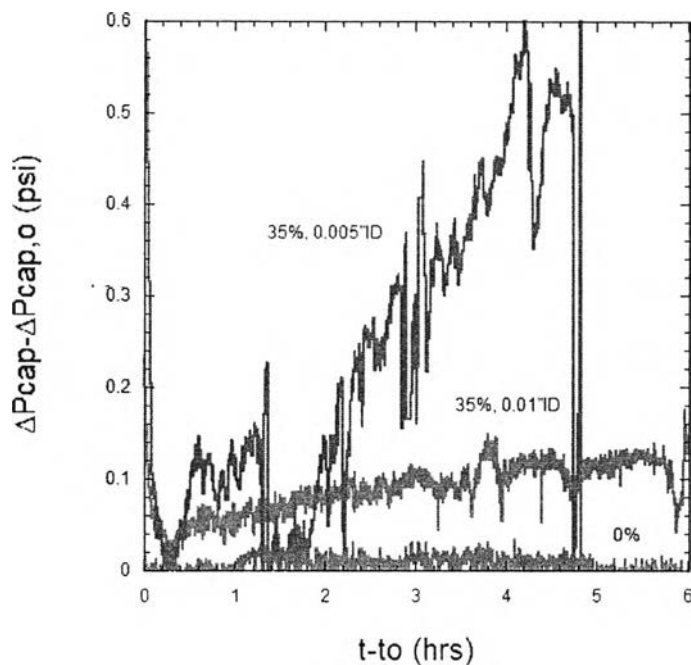

Figure 4.11 Pressure drop profile of 35% heptane at 60 °C in 0.01''ID and 0.005''ID capillaries.

4.5 Asphaltene Deposition Locations

Scanning electron microscopy was used to look at the deposit thickness along the length of the capillary. Experiments were performed by using zero dead volume unions to connect three 0.02 inch ID capillaries with a 2 inch length and a 0.02 inch ID capillary with a 1 foot length in series. Figure 4.12 shows the apparatus for this experiment. The experimental results indicate that the deposit was non-uniform along the length and thicker at the inlet. Figure 4.13 and Figure 4.14 show SEM images of capillaries inlet (left) and outlet (right) after an experiment performed with Oil A at 30% heptane in 0.02'' ID capillaries.

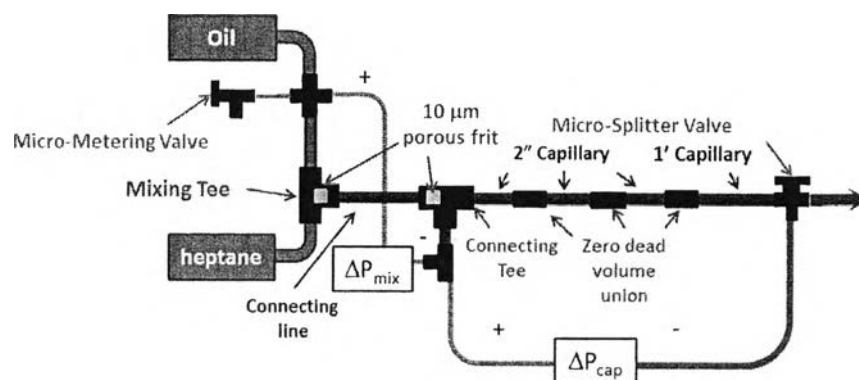

Figure 4.12 Asphaltene deposition apparatus to observe deposition thickness along the length.

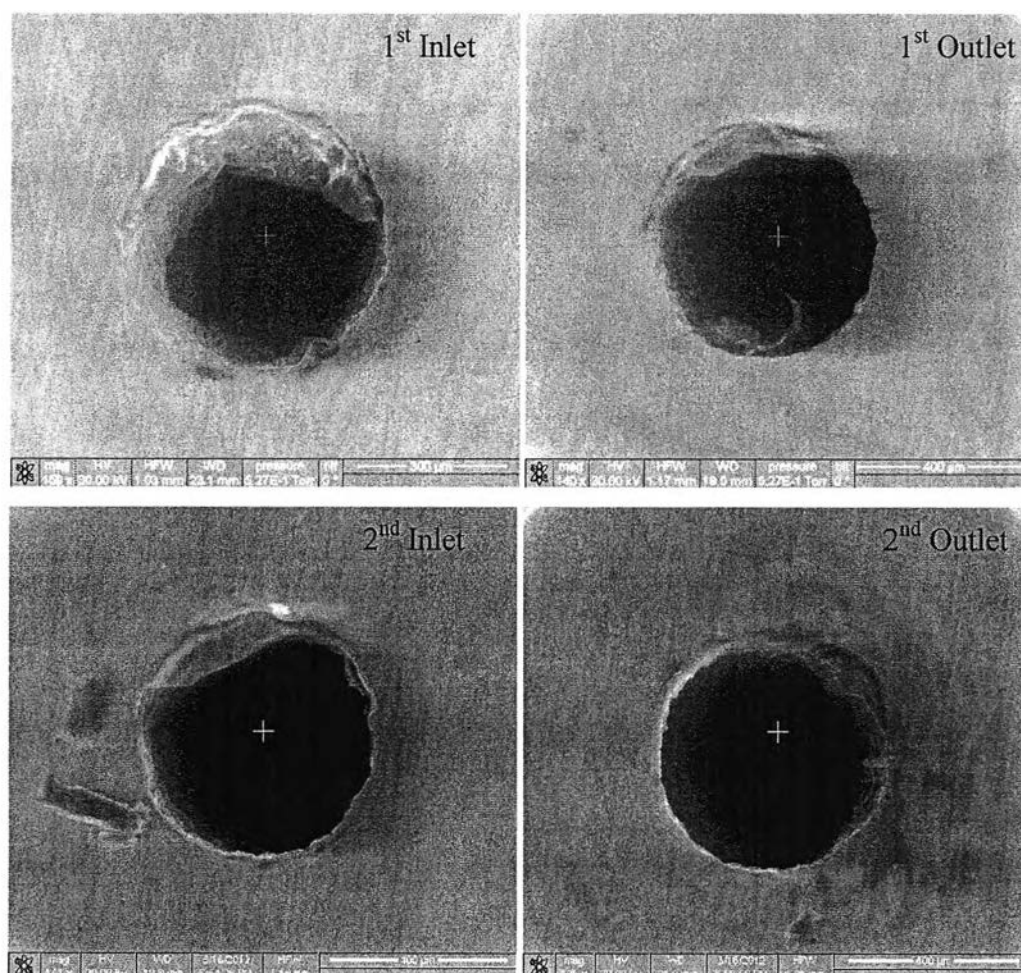

Figure 4.13 SEM images of 1st and 2nd capillary inlet and outlet for the Oil A deposit generated in a 0.02 inch ID capillary at 30% heptane.

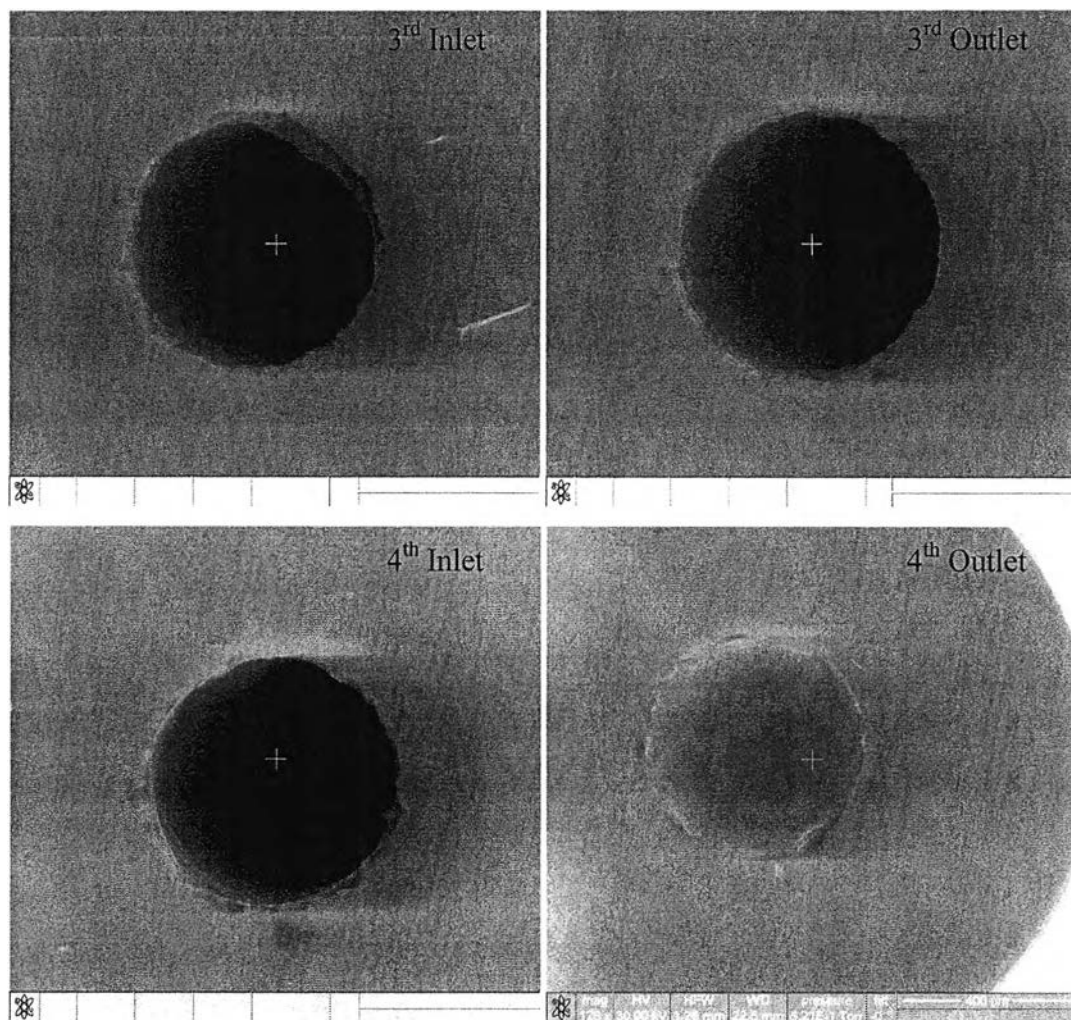

Figure 4.14 SEM images of 3rd and 4th capillary inlet and outlet for the Oil A deposit generated in a 0.02 inch ID capillary at 30% heptane.

SEM image of 4th capillary outlet shows that there may be trapped oil that has not been completely drained as can be seen from the blurry surface inside the capillary (the blurry image inside the capillary shown in Figure 4.14 is due to organic material inside the capillary, and not because of focus issues). To measure the mass of the deposit, each capillary section was weighed before and after the deposition experiment. Figure 4.15 shows the measured mass of deposit scaled by the capillary length of each. The results indicate that most of the mass occurs within the first 2 inches, which supports the result from SEM images. The significant amount of

measured mass of deposit in the last capillary section was believed to be oil that did not completely drain, as seen in Figure 4.14.

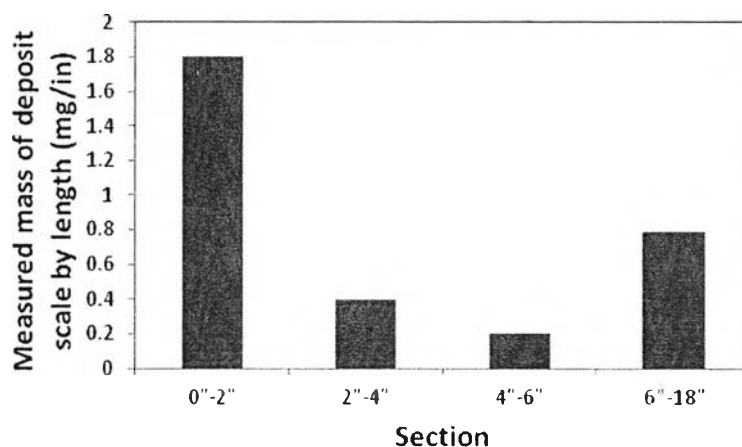

Figure 4.15 Measured mass of deposit in each capillary section of the Oil A deposit generated in a 0.02 inch ID capillary at 30% heptane.

4.6 Pressure Drop Prediction from SEM Deposit Thickness

To predict the pressure drop the Hagen-Poiseuille equation has been used. A great portion of the deposit is concentrated at the entrance of the capillary, as can be concluded by SEM images and measurement of the deposit weight. This result demonstrates that asphaltenes are preferentially to deposit as soon as they are destabilized. In the pressure drop calculations, we will assume that deposit occurs within the first 2 inches and continue throughout the length knowing that this will provide an estimate of the maximum possible pressure drop in the system. The final constricted radius was obtained from the SEM image by measuring the minimum final radius at the first capillary inlet in order to provide a conservative overestimate pressure drop. Table 4.1 shows the final constricted radius obtained from SEM image, calculated final pressure drop and the pressure drop obtained from the experiment. The result indicates that using the final constricted radius at the first capillary inlet still under predicts the final pressure drop obtained experimentally. One possible explanation for the under prediction is that despite efforts to preserve

the deposit during shutdown, some deposit still may be sheared away. It may occur that the deposit was lost during the shutdown process or some of the deposit may form inside the capillary where SEM cannot detect. Additionally, revalidation of the accuracy of the pressure transducer may be necessary.

Table 4.1 Calculated final pressure drop and pressure drop from experiment

Final constricted radius (μm)	Calculated final ΔP (m)	Measured ΔP (psi)
106	0.59	1.113

To investigate the second hypothesis, the mass of deposit has been calculated by assuming that deposit is linearly decreasing in thickness along the capillary length. The estimate mass of deposit was calculate based on the volume and the density of deposit. The density of asphaltene deposit was assumed to be 1.2 g/mL (Roux *et al.*, 2001). The volume of deposit was calculated by subtracting the volume of the capillary tube with the volume of truncate cone representing the volume occupied by the fluid in the first 2 inches. The volume of truncate cone was calculated by Equation 1.

$$V = \frac{\pi h}{3} * (R^2 + r^2 + R * r) \quad (1)$$

where R and r are the minimum final radius obtained from SEM images at the first capillary inlet and outlet, respectively. The capillary length is given by h.

Table 4.2 shows the volume of the capillary tube, the volume of truncate cone, calculated mass of deposit and the mass of deposit obtained from the experiment. The result indicates that using minimum final radius (thickest deposit) at the first capillary inlet and outlet provides the overestimate of mass of deposit. The accuracy of the estimate of the volume of deposit using minimum final radius (thickest deposit) is too imprecise to predict the mass axially, however knowing that the deposit was thicker at the inlet compare to at the outlet for all experiments. It is

unlikely to have non monotonic decreasing in thickness. The improving volume estimate from SEM would likely result in closer prediction for measured mass.

Table 4.2 Calculated mass of deposit and measured mass of deposit from the experiment

Volume of capillary tube (mL)	Volume of truncate cone (mL)	Calculated mass of deposit (g)	Measured mass of deposit (g)
0.0112	0.0039	0.0088	0.0036

4.7 Flowing Precipitated Asphaltene Solution Through a Capillary

To study the mechanism of asphaltene deposition, experiments were performed by flowing a previously precipitated asphaltene solution through a capillary. The asphaltene solution was aged for 23, 73 and 95 hours for the three experiments performed. The goal of this experiment is to observe whether precipitated asphaltenes with different size distributions can deposit in the capillary. The experimental results indicated that the asphaltene aged for 23 hours and 73 hours can deposit in the capillary. However the 95 hr aged asphaltenes, which is the longest aging time investigated here, do not deposit in a capillary as it can be seen from the pressure drop in Figure 4.16, which is constant as a function of time.

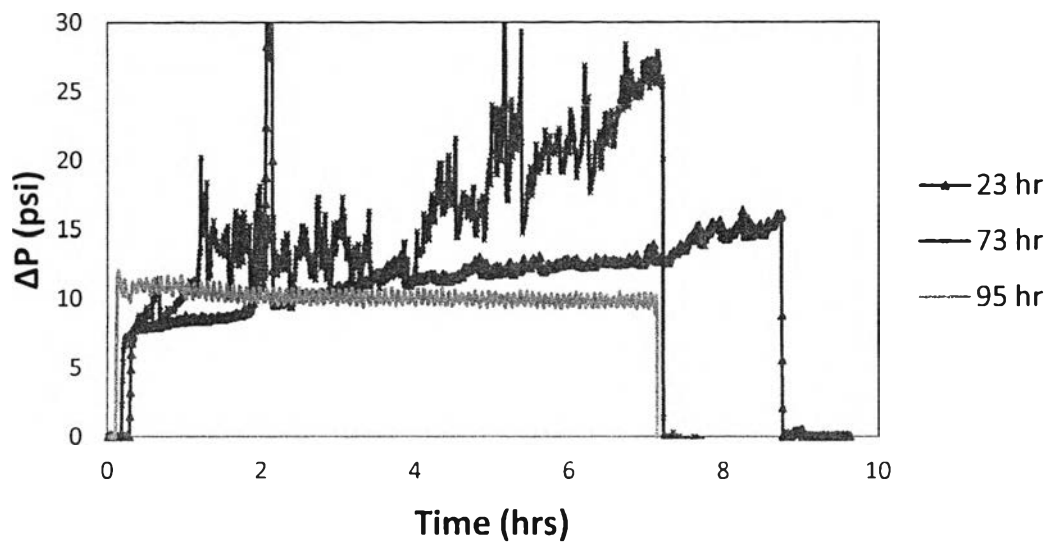

Figure 4.16 Flowing precipitated asphaltene solution through a capillary at 40 vol% heptane.

Maqbool *et al.* (2011) have shown that the asphaltenes continue to grow in size after being destabilized by alkane addition. If the oil-precipitant mixtures were left for enough time to grow, all of the small particle will be become larger as it can be seen from the particle size distribution of asphaltene particles as a function of time from this work in Figure 4.17.

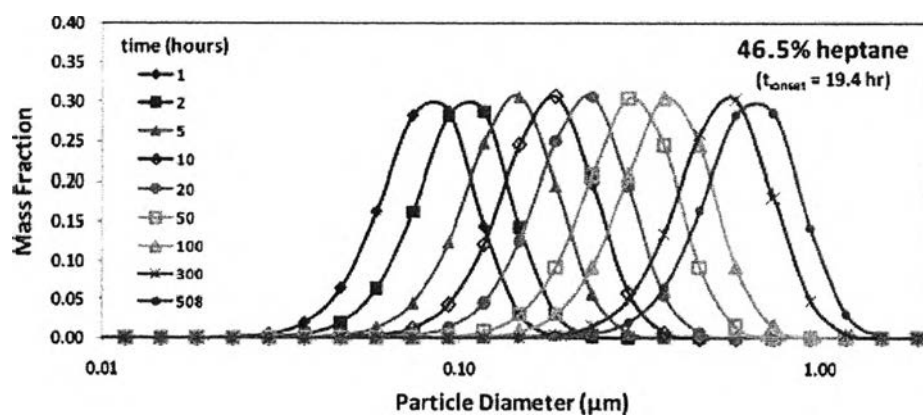

Figure 4.17 Particle size distribution of asphaltene particles as a function of time for 46.5 vol% heptane with K-1 crude oil (Maqbool *et al.*, 2011).

Hoepfner (2011) performed centrifugation experiments on the same crude oil, Oil A, and heptane concentration (40 vol% heptane) at room temperature. Figure 4.18 shows the amount of asphaltenes precipitated as a function of time from this work.

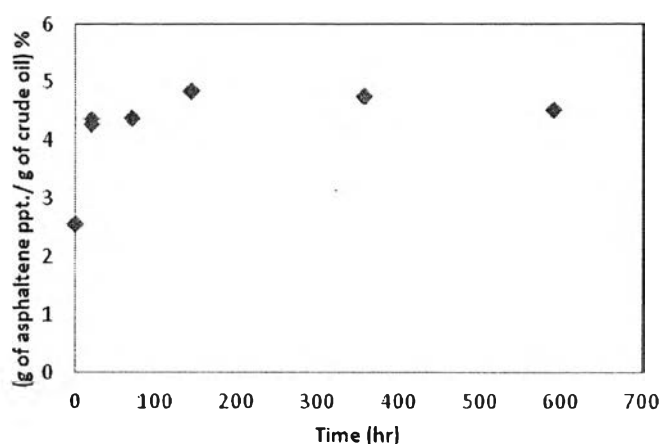

Figure 4.18 Amount of asphaltenes precipitated as a function of time using Oil A at 40 vol% heptane. (Hoepfner, 2011).

In this experiment, the amounts of precipitated asphaltenes increase and reach a plateau value after 24 hours. This plateau value corresponds to the equilibrium amount of asphaltenes that can be precipitated from a 40 vol% heptane in Oil A. After 24 hours the particles which are greater than $0.2 \mu\text{m}$ were completely separated by centrifugation technique, therefore only small particles were remained in the solution.

This result implies that the deposition of asphaltene caused by very small particles asphaltene during aggregation process and do not deposit after it was large enough or matured (95 hours aging time).